

Hitachi AMS 2000 Family Storage System

Site Preparation Guide

FASTFIND LINKS

Preface	Hitachi Full-Height Solutions Rack Specifications
Changes in this revision	EMEA Rack Specifications
Getting help	Hitachi AMS 47U Rack Specifications
Table of contents	High-density expansion unit specifications
Hitachi AMS 2000 Rack Specifications	Seismic rack specifications
	General specifications

Copyright © 2010 Hitachi Ltd., Hitachi Data Systems Corporation, ALL RIGHTS RESERVED

No part of this publication may be reproduced or transmitted in any form or by any means, electronic or mechanical, including photocopying and recording, or stored in a database or retrieval system for any purpose without the express written permission of Hitachi, Ltd. and Hitachi Data Systems Corporation (hereinafter referred to as "Hitachi").

Hitachi, Ltd. and Hitachi Data Systems reserve the right to make changes to this document at any time without notice and assume no responsibility for its use. Hitachi, Ltd. and Hitachi Data Systems products and services can only be ordered under the terms and conditions of Hitachi Data Systems' applicable agreements.

All of the features described in this document may not be currently available. Refer to the most recent product announcement or contact your local Hitachi Data Systems sales office for information on feature and product availability.

Notice: Hitachi Data Systems products and services can be ordered only under the terms and conditions of Hitachi Data Systems' applicable agreement(s). The use of Hitachi Data Systems products is governed by the terms of your agreement(s) with Hitachi Data Systems.

Hitachi is a registered trademark of Hitachi, Ltd. in the United States and other countries. Hitachi Data Systems is a registered trademark and service mark of Hitachi in the United States and other countries. All other trademarks, service marks, and company names are properties of their respective owners.



Table of contents

Preface	ix
Intended audience	x
Product version	x
Release notes and readme	x
Document revision level	x
Changes in this revision	xi
Document organization	xi
Referenced documents	xi
Document conventions	xii
Convention for storage capacity values	xiii
Accessing product documentation	xiii
Getting help	xix
Comments	xix
1 Introduction	1-1
Product description	1-2
Key features	1-2
AMS expansion and high-density expansion units	1-3
Support for solid-state drives	1-3
Intermixing SATA, SAS, and SSD drives	1-4
Green features	1-5
About the AMS 2100 storage system	1-5
About the AMS 2300 storage system	1-7
About the AMS 2500 storage system	1-9
About AMS expansion units	1-11
About AMS high-density expansion units	1-11
Battery expansion unit	1-13
Site preparation responsibilities	1-14
User responsibilities	1-14
Site/installation coordinator responsibilities	1-15
Facilities personnel responsibilities	1-15

Hitachi Data Systems responsibilities	1-15
2 Safety	2-1
General safety guidelines	2-2
Safety symbols	2-2
Work safety guidelines.	2-5
Warning about moving parts	2-6
Electrical safety.	2-6
Electrostatic safety	2-7
3 Rack mounting a storage system	3-1
Overview	3-2
Hitachi AMS 2000 Family racks	3-3
Installation and maintenance clearance areas	3-6
Power	3-6
Floor load rating	3-7
Types of PDU plugs	3-8
Power jumper cables	3-8
Specifications	3-9
Hitachi Full-Height Solutions racks	3-10
Installation and maintenance clearance areas	3-12
Power	3-12
Floor load rating	3-12
Specifications	3-13
Hitachi AMS 47U rack	3-16
Specifications	3-20
Using the Universal Rail Kit 19-inch rack-mount rail support kit	3-23
Safety information.	3-26
Observing safety guidelines	3-26
Preventing electric shock	3-27
Preventing electrostatic discharge	3-28
Fire	3-28
Working around rotating or moving parts.	3-28
Be aware of all potential hazards	3-28
Precautions when using the rack-mounted equipment.	3-29
Casters.	3-29
Rack stability	3-29
Weight and location considerations	3-29
Height considerations	3-31
Placing components in the rack.	3-31
Working with racks or components in the rack	3-32
Air vents and airflow	3-33
Blanking panels.	3-33
Cable guidelines	3-33

Power precautions	3-34
Grounding requirements	3-35
Environmental specifications	3-35
Preparing for installation	3-36
Planning considerations	3-36
Receiving considerations for the rack	3-37
Tools required	3-37
Checking the hardware	3-37
Casters	3-37
Leveling feet	3-38
Stabilizing the rack	3-38
Installing side stabilizer plates	3-41
Moving the rack	3-43
Securing multiple racks together with the baying kit	3-43
Rear baying instructions	3-46
Opening and closing the side panels	3-47
Installing rack equipment	3-47
Installation steps	3-47
Installing cage nuts	3-48
Installing and uninstalling the anti-tip stabilizing plates	3-48
Installing blanking panels	3-50
Rack-mounting AMS high-density expansion units	3-50
Post-installation considerations	3-50
Casters	3-50
Precautions for inspection and cleaning	3-51
EMEA rack	3-51
Specifications	3-56
Installation and maintenance clearance areas	3-57
4 Preparing the site	4-1
Facilities considerations	4-2
Selecting a site	4-2
Floor load ratings	4-3
Space requirements	4-3
Power considerations	4-3
Electrical requirements	4-4
Environmental requirements	4-4
Service clearance	4-4
Supported configurations	4-6
User-supplied items	4-6
Rack-mount considerations	4-8
AMS high-density expansion unit considerations	4-8
Server considerations	4-8
Storage features	4-9

5	Preparing for AMS high-density expansion units	5-1
	Overview	5-2
	Configuration rules	5-3
	AMS 2100 and AMS 2300 rules	5-3
	AMS 2500 rules	5-4
	Floor load ratings	5-5
	Installing AMS high-density expansion units in a rack	5-5
	Bill of materials	5-6
	Ordering checklist	5-6
	Shipping	5-9
	New systems	5-9
	Retuning equipment	5-10
	Installation and support	5-10
	High-density expansion unit specifications	5-10
6	DC-powered racks	6-1
	Overview	6-2
	System components	6-4
	Seismic rack	6-4
	Installation prerequisites	6-5
	NEBS-3 requirements (USA)	6-5
	Rack and assembly	6-5
	Anchoring the rack	6-6
	Shelf level configuration	6-6
	Bonding and grounding	6-6
	Wiring and cabling	6-6
	NEBS-3 testing	6-7
	NEBS-3 test results and certification	6-7
	ETSI requirements (Europe)	6-7
	ETSI testing	6-7
	ETSI test results and certification	6-7
	Installation	6-8
	Installing a seismic rack	6-8
	Anchoring the rack	6-8
	Anchoring kit	6-8
	Grounding the rack components	6-9
	Mounting components in the rack	6-10
	Fasteners	6-10
	Paint piercing lock washers	6-10
	Seismic rack specifications	6-11
	Regulatory compliance	6-13
	Certifications	6-14
	Drawings	6-16

A	General specifications	A-1
	Dimensions and weight	A-2
	Environmental specifications	A-3
	Electrical requirements	A-3
	Regulatory compliance	A-4
	Safety certification	A-4
	iSCSI connection specifications	A-5
B	Installation planning checklist	B-1



Preface

This document provides facilities requirements for preparing and installing Hitachi Adaptable Modular Storage (AMS) 2100, 2300, and 2500 storage systems. In this document, these storage systems are referred to collectively as the Hitachi AMS 2000 Family storage systems. If information pertains to certain members of this family, those systems are identified.

Using this document, you will be able to prepare your site for the arrival and installation of your units. To determine the total components your shipment will include, please consult your Hitachi Data Systems representative.

This preface includes the following information:

- [Intended audience](#)
- [Product version](#)
- [Release notes and readme](#)
- [Document revision level](#)
- [Changes in this revision](#)
- [Document organization](#)
- [Referenced documents](#)
- [Document conventions](#)
- [Convention for storage capacity values](#)
- [Accessing product documentation](#)
- [Getting help](#)
- [Comments](#)

Intended audience

This document is intended for personnel who will schedule, manage, and perform the tasks required to prepare your site for installing a Hitachi AMS 2000 Family storage systems.

Product version

This document applies to Hitachi AMS 2000 Family firmware version 0890/A or later.

Release notes and readme

Read the release notes and readme file before installing and using this product. They may contain requirements or restrictions that are not fully described in this document and/or updates or corrections to this document.

Document revision level

This section provides a history of the revision changes to this document.

Revision	Date	Description
MK-98DF8149EN-00	October 2008	Initial Release
MK-98DF8149EN-01	October 2008	Revision 1, supersedes and replaces MK-98DF8149EN-00
MK-98DF8149EN-02	December 2008	Revision 2, supersedes and replaces MK-98DF8149EN-01
MK-98DF8149EN-03	February 2009	Revision 3, supersedes and replaces MK-98DF8149EN-02
MK-98DF8149EN-04	April 2009	Revision 4, supersedes and replaces MK-98DF8149EN-03
MK-98DF8149EN-05	May 2009	Revision 5, supersedes and replaces MK-98DF8149EN-04
MK-98DF8149EN-06	August 2009	Revision 6, supersedes and replaces MK-98DF8149EN-05
MK-98DF8149EN-07	November 2009	Revision 7, supersedes and replaces MK-98DF8149EN-06
MK-98DF8149EN-08	January 2010	Revision 8, supersedes and replaces MK-98DF8149EN-07
MK-98DF8149EN-09	April 2010	Revision 9, supersedes and replaces MK-98DF8149EN-08

Changes in this revision

- Added information about Solid State Drives to [Chapter 1, Introduction](#).
- Added information about SAS high-density expansion tray under [Intermixing SATA, SAS, and SSD drives on page 1-4](#).
- Removed instances of 4 GB Fibre Channel port information and added 8 GB Fibre Channel port information under [About the AMS 2100 storage system on page 1-5](#), [About the AMS 2300 storage system on page 1-7](#), and [About the AMS 2500 storage system on page 1-9](#).
- Added new [Figure 1-1 on page 1-12](#).
- Added the new section [Battery expansion unit on page 1-13](#).
- Added the new section [Hitachi AMS 47U rack on page 3-16](#).
- Revised the note under [Height considerations on page 3-31](#) to indicate that 2U is reserved at the base of the rack for possible battery units or for ENC cabling in the case of high-density expansion units.

Document organization

The following table provides an overview of the contents and organization of this document. Click the [chapter title](#) in the first column to go to that chapter. The first page of every chapter or appendix contains a brief list of the contents of that section of the manual, with links to the pages where the information is located.



Chapter/Appendix Title	Description
Chapter 1, Introduction	Provides an overview of the Hitachi AMS 2000 Family storage systems and the shared responsibilities for installing them.
Chapter 2, Safety	Provides important safety to follow before and during the installation procedure.
Chapter 3, Rack mounting a storage system	Describes the key hardware components on the Hitachi AMS 2000 Family storage systems.
Chapter 4, Preparing the site	Describes how to prepare the site for installing Hitachi AMS 2000 Family storage systems.
Chapter 5, Preparing for AMS high-density expansion units	Provides site-preparation guidelines for AMS high-density expansion units.
Chapter 6, DC-powered racks	Describes the DC-powered racks that can be used to install DC-powered AMS 2500 storage systems.
Appendix A, General specifications	Lists the key specifications for Hitachi AMS 2000 Family storage systems.
Appendix B, Installation planning checklist	Provides a checklist for verifying that all installation requirements for Hitachi AMS 2000 Family storage systems have been met.

Referenced documents

- *AMS 2100/2300 Storage System Hardware Guide*, MK-97DF8010
- *Hitachi AMS 2500 Storage System Hardware Guide*, MK-97DF8007

Document conventions

This document uses the following symbols to draw attention to important safety and operational information.

Symbol	Meaning	Description
	Tip	Tips provide helpful information, guidelines, or suggestions for performing tasks more effectively.
	Note	Notes emphasize or supplement important points of the main text.
	Caution	Cautions indicate that failure to take a specified action could result in damage to the software or hardware.

The following typographic conventions are used in this document.

Convention	Description
Bold	Indicates text on a window, other than the window title, including menus, menu options, buttons, fields, and labels. Example: Click OK .
<i>Italic</i>	Indicates a variable, which is a placeholder for actual text provided by the user or system. Example: copy <i>source-file target-file</i> Angled brackets (< >) are also used to indicate variables.
screen/code	Indicates text that is displayed on screen or entered by the user. Example: # pairdisplay -g oradb
< > angled brackets	Indicates a variable, which is a placeholder for actual text provided by the user or system. Example: # pairdisplay -g <group> Italic font is also used to indicate variables.
[] square brackets	Indicates optional values. Example: [a b] indicates that you can choose a, b, or nothing.
{ } braces	Indicates required or expected values. Example: { a b } indicates that you must choose either a or b.
vertical bar	Indicates that you have a choice between two or more options or arguments. Examples: [a b] indicates that you can choose a, b, or nothing. { a b } indicates that you must choose either a or b.
underline	Indicates the default value. Example: [<u>a</u> b]

Convention for storage capacity values

Physical storage capacity values (e.g., disk drive capacity) are calculated based on the following values:

Physical capacity unit	Value
1 KB	1,000 bytes
1 MB	1,000 KB or 1,000 ² bytes
1 GB	1,000 MB or 1,000 ³ bytes
1 TB	1,000 GB or 1,000 ⁴ bytes
1 PB	1,000 TB or 1,000 ⁵ bytes
1 EB	1,000 PB or 1,000 ⁶ bytes

Logical storage capacity values (e.g., logical device capacity) are calculated based on the following values:

Logical capacity unit	Value
1 block	512 bytes
1 KB	1,024 (2 ¹⁰) bytes
1 MB	1,024 KB or 1024 ² bytes
1 GB	1,024 MB or 1024 ³ bytes
1 TB	1,024 GB or 1024 ⁴ bytes
1 PB	1,024 TB or 1024 ⁵ bytes
1 EB	1,024 PB or 1024 ⁶ bytes

Accessing product documentation

The AMS 2000 Family user documentation is available on the Hitachi Data Systems Portal: <https://portal.hds.com>. Please check this site for the most current documentation, including important updates that may have been made after the release of the product.

This documentation set consists of the following documents.

Release notes

- Adaptable Modular Storage System Release Notes
- Storage Navigator Modular 2 Release Notes



Please read the release notes before installing and/or using this product. They may contain requirements and/or restrictions not fully described in this document, along with updates and/or corrections to this document.

Installation and getting started

The following documents provide instructions for installing an AMS 2000 Family storage system. They include rack information, safety information, site-preparation instructions, getting-started guides for experienced users, and host connectivity information. The symbol  identifies documents that contain initial configuration information about Hitachi AMS 2000 Family storage systems.

 **AMS2100/2300 Getting Started Guide**, MK-98DF8152

Provides quick-start instructions for getting an AMS 2100 or AMS 2300 storage system up and running as quickly as possible.

 **AMS2500 Getting Started Guide**, MK-97DF8032

Provides quick-start instructions for getting an AMS 2500 storage system up and running as quickly as possible.

AMS 2000 Family Site Preparation Guide, MK-98DF8149 — this document

Contains initial site planning and pre-installation information for AMS 2000 Family storage systems, expansion units, and high-density expansion units. This document also covers safety precautions, rack information, and product specifications.

AMS 2000 Family Fibre Channel Host Installation Guide, MK-08DF8189

Describes how to prepare Hitachi [AMS 2000 Family](#) Fibre Channel storage systems for use with host servers running supported operating systems.

AMS 2000 Family iSCSI Host Installation Guide, MK-08DF8188

Describes how to prepare Hitachi [AMS 2000 Family](#) iSCSI storage systems for use with host servers running supported operating systems.

Storage and replication features

The following documents describe how to use Storage Navigator Modular 2 (Navigator 2) to perform storage and replication activities.

Storage Navigator 2 Advanced Settings User's Guide, MK-97DF8039

Contains advanced information about launching and using Navigator 2 in various operating systems, IP addresses and port numbers, server certificates and private keys, boot and restore options, outputting configuration information to a file, and collecting diagnostic information.

Storage Navigator Modular 2 User's Guide, MK-99DF8208

Describes how to use Navigator 2 to configure and manage storage on an AMS 2000 Family storage system.

AMS 2000 Family Dynamic Provisioning Configuration Guide, MK-09DF8201

Describes how to use virtual storage capabilities to simplify storage additions and administration.

Storage Navigator 2 Storage Features Reference Guide for AMS, MK-97DF8148

Contains concepts, preparation, and specifications for Account Authentication, Audit Logging, Cache Partition Manager, Cache Residency Manager, Data Retention Utility, LUN Manager, Performance Monitor, SNMP Agent, and Modular Volume Migration.

AMS 2000 Family Copy-on-write SnapShot User Guide, MK-97DF8124

Describes how to create point-in-time copies of data volumes in AMS 2100, AMS 2300, and AMS 2500 storage systems, without impacting host service and performance levels. Snapshot copies are fully read/write compatible with other hosts and can be used for rapid data restores, application testing and development, data mining and warehousing, and nondisruptive backup and maintenance procedures.

AMS 2000 Family ShadowImage In-system Replication User Guide, MK-97DF8129

Describes how to perform high-speed nondisruptive local mirroring to create a copy of mission-critical data in AMS 2100, AMS 2300, and AMS 2500 storage systems. ShadowImage keeps data RAID-protected and fully recoverable, without affecting service or performance levels. Replicated data volumes can be split from host applications and used for system backups, application testing, and data mining applications while business continues to operate at full capacity.

AMS 2000 Family TrueCopy Remote Replication User Guide, MK-97DF8052

Describes how to create and maintain multiple duplicate copies of user data across multiple AMS 2000 Family storage systems to enhance your disaster recovery strategy.

AMS 2000 Family TrueCopy Extended Distance User Guide,
MK-97DF8054

Describes how to perform bi-directional remote data protection that copies data over any distance without interrupting applications, and provides failover and recovery capabilities.

AMS 2000 Data Retention Utility User's Guide, MK-97DF8019

Describes how to lock disk volumes as read-only for a certain period of time to ensure authorized-only access and facilitate immutable, tamper-proof record retention for storage-compliant environments. After data is written, it can be retrieved and read only by authorized applications or users, and cannot be changed or deleted during the specified retention period.

Storage Navigator Modular 2 online help

Provides topic and context-sensitive help information accessed through the Navigator 2 software.

Hardware maintenance and operation

The following documents describe how to operate, maintain, and administer an AMS 2000 Family storage system. They also provide a wide range of technical information and specifications for the AMS 2000 Family storage systems. The symbol  identifies documents that contain initial configuration information about Hitachi AMS 2000 Family storage systems.

 **AMS 2100/2300 Storage System Hardware Guide,** MK-97DF8010

Provides detailed information about installing, configuring, and maintaining AMS 2100 and 2300 storage systems.

 **AMS 2500 Storage System Hardware Guide,** MK-97DF8007

Provides detailed information about installing, configuring, and maintaining an AMS 2500 storage system.

 **AMS 2000 Family Storage System Reference Guide,** MK-97DF8008

Contains specifications and technical information about power cables, system parameters, interfaces, logical blocks, RAID levels and configurations, and regulatory information about AMS 2100, AMS 2300, and AMS 2500 storage systems. This document also contains remote adapter specifications and regulatory information.

AMS 2000 Family Storage System Service and Upgrade Guide,
MK-97DF8009

Provides information about servicing and upgrading AMS 2100, AMS 2300, and AMS 2500 storage systems.

AMS 2000 Family Power Savings User Guide, MK-97DF8045

Describes how to spin down volumes in selected RAID groups when they are not being accessed by business applications to decrease energy consumption and significantly reduce the cost of storing and delivering information.

Command and Control (CCI)

The following documents describe how to install the Hitachi AMS 2000 Family Command Control Interface (CCI) and use it to perform TrueCopy and ShadowImage operations.

AMS 2000 Family Command Control Interface (CCI) Installation Guide, MK-97DF8122

Describes how to install CCI software on open-system hosts.

AMS 2000 Family Command Control Interface (CCI) Reference Guide, MK-97DF8121

Contains reference, troubleshooting, and maintenance information related to CCI operations on AMS 2100, AMS 2300, and AMS 2500 storage systems.

AMS 2000 Family Command Control Interface (CCI) User's Guide,
MK-97DF8123

Describes how to use CCI to perform TrueCopy and ShadowImage operations on AMS 2100, AMS 2300, and AMS 2500 storage systems.

Command Line Interface (CLI)

The following documents describe how to use Hitachi Storage Navigator Modular 2 to perform management and replication activities from a command line.

Storage Navigator Modular 2 Command Line Interface (CLI) Unified Reference Guide, MK-97DF8089

Describes how to interact with all Navigator 2 bundled and optional software modules by typing commands at a command line.

Storage Navigator 2 Command Line Interface Replication Reference Guide for AMS, MK-97DF8153

Describes how to interact with Navigator 2 to perform replication activities by typing commands at a command line.

Dynamic Replicator documentation

The following documents describe how to install, configure, and use Hitachi Dynamic Replicator to provide AMS Family storage systems with continuous data protection, remote replication, and application failover in a single, easy-to-deploy and manage platform.

Dynamic Replicator - Scout Release Notes, RN-99DF8211

Dynamic Replicator - Scout Host Administration Guide,
MK-98DF8212

Dynamic Replicator - Scout Installation and Configuration Guide,
MK-

Dynamic Replicator - Scout Quick Start Guide, MK-98DF8214

Dynamic Replicator - Scout Host Troubleshooting Guide,
MK-98DF8215

Dynamic Replicator DR-Scout ICAT Utility Guide, MK-98DF8216

Dynamic Replicator - Scout RX Server Deployment Guide,
MK-98DF8217

Dynamic Replicator VX Solution for Oracle (Solaris), MK-98DF8218

Dynamic Replicator - Scout Solution for SharePoint 2007,
MK-98DF8219

Dynamic Replicator - Scout Solution for MySQL (Windows),
MK-98DF8220

**Protecting Citrix XenServer Using Hitachi Dynamic Replicator -
Scout**, MK-98DF8221

Dynamic Replicator Quick Install/Upgrade Guide, MK-98DF8222

Dynamic Replicator - Scout Protecting MS SQL Server, MK-98DF8223

Dynamic Replicator - Scout - Protecting Microsoft Exchange Server,
MK-98DF8224

Dynamic Replicator - Scout File Server Solution, MK-98DF8225

Dynamic Replicator - Scout ESX - Protecting ESX Server (RCLI),
MK-99DF8226

Getting help

If you need to contact the Hitachi Data Systems support center, please provide as much information about the problem as possible, including:

- The circumstances surrounding the error or failure.
- The exact content of any messages displayed on the host system(s).
- The exact content of any messages displayed on Storage Navigator Modular 2.
- The Storage Navigator Modular 2 configuration information. This information is used by service personnel for troubleshooting purposes.

The Hitachi Data Systems customer support staff is available 24 hours a day, seven days a week. If you need technical support, please log on to the Hitachi Data Systems Portal for contact information: <https://portal.hds.com>

Comments

Please send us your comments on this document: doc.comments@hds.com. Include the document title, number, and revision, and refer to specific section(s) and paragraph(s) whenever possible.

Thank you! (All comments become the property of Hitachi Data Systems.)

Introduction

The required installation planning tasks for the Hitachi Adaptable Modular Storage (AMS) 2000 Family storage systems must be completed before your system arrives to ensure a successful and efficient installation. As your trusted storage partner, Hitachi Data Systems shares with users the responsibilities associated with installing base, expansion, and high-density expansion units for AMS 2000 Family storage systems.

This chapter identifies the site planning responsibilities for users and Hitachi Data Systems. It also provides an overview of the AMS 2100/2300/2500 base, expansion, and high-density expansion units and summarizes their key features. The key topics in this chapter are:

- ❑ [Product description](#)
- ❑ [Key features](#)
- ❑ [About the AMS 2100 storage system](#)
- ❑ [About the AMS 2300 storage system](#)
- ❑ [About the AMS 2500 storage system](#)
- ❑ [About AMS expansion units](#)
- ❑ [Battery expansion unit](#)
- ❑ [Site preparation responsibilities](#)

Product description

The Hitachi AMS 2000 Family storage systems are highly versatile, highly scalable, and easy-to-use storage solutions that reduce storage management complexity, cost, and risk and offer the highest levels of performance, availability, scalability, and reliability. The units boast easy-to-use software wizards and Web-based tools for configuring, managing, and maintaining your storage.

The Hitachi AMS 2000 Family storage systems consist of a base unit and one or more AMS expansion units or AMS high-density expansion units:

- AMS expansion and/or high-density expansion units are optional for AMS 2100 and AMS 2300 storage systems.
- AMS expansion and/or high-density expansion units are required for AMS 2500 storage systems.

Key features

Hitachi AMS 2000 Family storage systems deliver more cost-effective options for increased data protection and disaster recovery than competing products. This advantage provides a comprehensive data life cycle management solution that allows cost-conscious users to match and deploy the right class of storage for their application requirements, resulting in a lower storage total cost of ownership.

The following list summarizes the key features offered by the Hitachi AMS 2000 Family storage systems:

- Pay-as-you-grow scalability by hot-adding AMS expansion units and/or AMS high-density expansion units
- Switched point-to-point architecture eliminates bottlenecks when delivering data to/from drives and cache and on to the server — ideal for environments with multiple servers and offering greater flexibility in designing storage networks
- Supports Fibre Channel and iSCSI multiprotocols simultaneously on all models
- Superior flexibility for handling any workload requirements
- Supports RAID 0, RAID 0+1, RAID 5, and RAID 6, or an intermix of these RAID levels
- Failover support with load balancing moves workloads to the second controller following a disruption to one controller or network connection
- Active-active design reduces management complexities
- AMS base and expansion units can be installed and maintained by users
- Tool-free end-user maintenance

AMS expansion and high-density expansion units

Effective storage implementations require good configuration and capacity planning. To that end, it is critical to know your existing storage requirements and to anticipate what those requirements will be in a year or two to ensure that the solution being applied today will meet your storage projections for that timeframe.

A significant benefit of the Hitachi AMS 2000 Family storage systems is that you do not have to buy all of your storage at once. You can buy enough capacity to meet your current needs, and gradually scale your storage over time by adding AMS expansion units and AMS high-density expansion units to accommodate increasing demands as needed.

Best of all, the additional capacity can be made available by daisy-chaining the AMS expansion units or AMS high-density expansion units to the system. AMS expansion units and AMS high-density expansion units can be intermixed within the same AMS system. AMS expansion units and AMS high-density expansion units support RAID 1, 1+0, 5, and 6.

Support for solid-state drives

Hitachi AMS 2000 Family storage systems support solid-state drives (SSDs). SSDs are not supported as the first five drives in AMS 2100, AMS 2300, and AMS 2500 storage systems. The minimum number of SSDs supported in a system is three (RAID1+1+spare.)

SSDs are electrically, mechanically, and software compatible with a conventional (magnetic) hard disk. The difference is that the storage medium is not magnetic (like a hard disk) or optical (like a CD), but solid-state semiconductor such as battery-backed RAM, EPROM, or other electrically erasable RAM-like chip. This provides faster access time than a SATA or SAS drive, because the data can be randomly accessed and does not rely on a read/write interface head synchronizing with a rotating disk.

SSDs are significantly faster than conventional rotating hard drives. This translates into higher I/O rates, making them ideal for applications where I/O response time is critical. In particular, SSDs are the perfect repository for storing data that has the potential for creating bottlenecks, such as databases, swap files, library and index files, and authorization and login information.

Although SSDs outperform SATA and SAS hard drives, their random read performance is significantly different (and faster) than their random write performance. This performance gap is due to a collection of bytes called an "erase block" inside the drive. When you write to a SSD, the drive does not just update the sectors you are changing, but merges your changes with existing data to update a complete erase block. These erase blocks can cause random write operations to be nearly three times faster than SSD read operations. In addition, RAID 5 random write operations perform

several SSD read and write cycles to accomplish their task. As a result, SSDs offer a better return on investment for random read operations than for random write operations.

SSDs also provide greater physical resilience to physical vibration, shock, and extreme temperature fluctuations.

The following list summarizes the advantages of SSDs.

- Faster start-up, as no spin-up is required.
- Typically fast random access for reading, as there is no read/write head to move.
- Extremely low read latency times, as SSD seek-times are orders of magnitude lower than the best hard drives. In applications where hard drive seeks are the limiting factor, this results in faster boot and application launch times.
- Unlike hard disk drives, performance of SSDs is almost constant and deterministic across the entire storage. This is because the seek time is almost instant and does not depend on the physical location of the data. As a result, file fragmentation has almost no impact on read performance.
- With no moving parts, SSDs typically consume significantly less power and generate very little heat compared to hard disk drives.
- High mechanical reliability, as the lack of moving parts nearly eliminates the risk of “mechanical” failure.
- Ability to endure extreme shock, high altitude, vibration and extremes of temperature because there are no moving parts.

Intermixing SATA, SAS, and SSD drives

Hitachi AMS base and expansion units support a combination of SATA, SAS, and SSD drives within the same enclosure. This unparalleled flexibility allows you to choose between trusted lower-cost, high-density SATA drives; high-performance SAS drives; and dependable SSDs. Or if you can't decide, you can use them all in a single enclosure that seamlessly supports all three types of drives. In this way, you can mix and match drive technologies and fine tune system performance, reliability, and price to meet low-cost, high-performance, or dependability requirements — or even all three — at the same time.

A high-density expansion unit contains either all SATA drives or all SAS drives. At this time, you cannot intermix SATA and SAS drives in the same high-density expansion unit, or install SSDs in high-density expansion units. You can, however, intermix 450 GB (when available) and 600 GB SAS drives in the same high-density expansion unit.

For more information, refer to the *AMS 2100/2300 Storage System Hardware Guide* and *AMS 2500 Storage System Hardware Guide*.

Green features

All Hitachi AMS 2000 Family storage systems offer a “green” storage platform that is fully RoHS (reduction of hazardous sources) compliant and energy efficient. The hard disk drives on all Hitachi AMS 2000 Family storage systems, for example, have the ability to spin down to conserve power. The spin-down feature is especially effective for applications that experience large blocks of idle time when there is no activity, including e-mail archiving, disk-to-disk backup, virtual tape libraries, file transfer services, file and print servers, and other applications that spend up to 75 percent to 90 percent of their time idle, where there is no activity. The spin down feature presents an opportunity to reduce power and cooling costs.

in addition to powering down drives, AMS 2000 Family storage systems boast additional power-saving features, such as:

- Power supplies that supply only the power needed
- Variable-speed fans that spin only at the rate needed to cool the unit to its optimal temperature

About the AMS 2100 storage system

The AMS 2100 storage system consists of a base unit that includes:

- Two redundant power supplies and two redundant controllers
- Two cache backup batteries
- One of the following port configurations, based on controller version:
 - Version 1 controller: Either four 4 Gb Fibre Channel ports (two per controller) or four 1 Mbps iSCSI ports (two per controller)
 - Version 2 controller: Eight 8 Gb Fibre Channel ports (four per controller) and four iSCSI 1 Gbps ports (two per controller)
 - 4 Gb Fibre Channel ports support fallback speed of 2 Gb.
 - 8 Gb Fibre Channel ports support fallback speeds of 4 Gb and 2 Gb.
 - All Fibre Channel ports use multi-mode Fibre Channel cables.
 - iSCSI ports work with standard Category 5e or Category 6 Ethernet LAN cables.
- Two management ports and two maintenance ports
- 8 GB cache (2 x 4 GB)
- From four to 15 disk drives (minimum of four SATA or SAS drives are required in the system tray; SSDs are not permitted in these slots)

For greater performance and capacity, you can add the following options:

- Two additional 8 Gb Fibre Channel ports per each Version 2 controller.
- Two 1 Gbps full-duplex Ethernet (1000Base-T) iSCSI data ports per each Version 2 controller.
- An AMS expansion unit (see [About AMS expansion units on page 1-11](#)).

- An AMS high-density expansion unit (see [About AMS high-density expansion units on page 1-11](#)).

For more information, refer to the *AMS 2100/2300 Storage System Hardware Guide*.

Table 1-1: AMS 2100 Minimum and Maximum Configurations

Base Unit		Expansion Unit				
SATA/SAS Disk Drives		Type	Units		SATA/SAS Disk Drives	
Minimum	Maximum		Minimum	Maximum	Minimum	Maximum
4	15	Expansion Unit	0	7	2 per unit	15 per expansion unit
		High-density expansion Unit	0	3	2 in each section of the unit (see text below)	48 SATA or 38 SAS per expansion unit
Base Unit		Expansion Unit				
SSDs		Type	Units		SSDs	
Minimum	Maximum		Minimum	Maximum	Minimum	Maximum
3	15	Expansion Unit	0	7	2 per unit	15 per expansion unit (see text below)
		High-density expansion Unit	N/A	N/A	N/A	N/A

Minimum supported HDS configuration is two disk drives installed in slots 0 and 1 in side A, and two drives installed in slots 0 and 1 in side B. To locate sides A and B, refer to either:

- The left or right side when facing the front of the unit, or
- The label at the top rear area of the AMS 2100 high-density expansion unit.

The AMS 2100 array supports up to 15 SSDs per system. SSDs can be installed in the base unit, expansion unit, or intermixed in both the base and expansion units per above minimum and maximum specifications. High-density expansion units support SATA or SAS drives only. The minimum number of SSDs supported in a system is three (RAID1+1+spare.) SSDs are not supported as the first five drives in AMS 2100 storage systems.

About the AMS 2300 storage system

The AMS 2300 storage system consists of a base unit that includes:

- Two redundant power supplies and two redundant controllers
- Two cache backup batteries
- One of the following port configurations, based on controller version:
 - Version 1 controller: Either four 4 Gb Fibre Channel ports (two per controller) or four 1 Mbps iSCSI ports (two per controller)
 - Version 2 controller: Sixteen 8 Gb Fibre Channel ports (eight per controller) and four iSCSI 1 Gbps ports (two per controller)
 - 4 Gb Fibre Channel ports support fallback speed of 2 Gb.
 - 8 Gb Fibre Channel ports support fallback speeds of 4 Gb and 2 Gb.
 - All Fibre Channel ports use multi-mode Fibre Channel cables.
 - iSCSI ports work with standard Category 5e or Category 6 Ethernet LAN cables.
- Two management ports and two maintenance ports
- 16 GB cache (4 x 4 GB)
- From four to 15 disk drives (minimum of four SATA or SAS drives are required in the system tray; SSDs are not permitted in these slots)

For greater performance and capacity, you can add the following options:

- Four additional 8 Gb Fibre Channel ports per each Version 2 controller.
- Two 1 Gbps full-duplex Ethernet (1000Base-T) iSCSI data ports per each Version 2 controller.
- From 1 to 15 AMS expansion units (see [About AMS expansion units on page 1-11](#)).
- From 1 to 4 AMS high-density expansion units (see [About AMS high-density expansion units on page 1-11](#)).

For more information, refer to the *AMS 2100/2300 Storage System Hardware Guide*.

Table 1-2: AMS 2300 Minimum and Maximum Configurations

Base Unit		Expansion Unit				
SATA/SAS Disk Drives		Type	Units		SATA/SAS Disk Drives	
Minimum	Maximum		Minimum	Maximum	Minimum	Maximum
4	15	Expansion Unit	0	15	2 per unit	15 per unit
		High-density Expansion Unit	0	4	2 in each section of the unit (see text below)	48 SATA or 38 SAS per expansion unit
Base Unit		Expansion Unit				
SSDs		Type	Units		SSDs	
Minimum	Maximum		Minimum	Maximum	Minimum	Maximum
3	15	Expansion Unit	0	15	2 per unit	15 per expansion unit (see text below)
		High-density Expansion Unit	N/A	N/A	N/A	N/A

Minimum supported HDS configuration is two disk drives installed in slots 0 and 1 in side A, and two drives installed in slots 0 and 1 in side B. The AMS 2300 array supports up to 15 SSDs per system. Minimum supported HDS configuration is two disk drives installed in slots 0 and 1 in side A, and two drives installed in slots 0 and 1 in side B. To locate sides A and B, refer to either:

- The left or right side of the unit when facing the front of the unit, or
- The label at the top rear area of the AMS 2300 high-density expansion unit

SSDs can be installed in the base unit, expansion unit, or intermixed in both the base and expansion units per above minimum and maximum specifications. High-density expansion units support SATA or SAS drives only. The minimum number of SSDs supported in a system is three (RAID1+1+spare.) SSDs are not supported as the first five drives in AMS 2300 storage systems.

About the AMS 2500 storage system

The AMS 2500 storage system consists of a base unit that provides connection, control, and management of the array. The base unit hardware includes:

- Two redundant power supplies and two redundant controllers
- Four cache backup batteries
- Two fan units
- Sixteen 8 Gb Fibre Channel ports (eight per controller) that support fallback speeds of 4 Gb and 2 Gb. All Fibre Channel ports use multi-mode Fibre Channel cables.
- Eight 1 Gbps full-duplex Ethernet (1000Base-T) iSCSI data ports (four per controller). These ports work with standard Category 5e or Category 6 Ethernet LAN cables.
- Two management ports and two maintenance ports
- 32 GB cache (8 x 4 GB)

The AMS 2500 is also equipped with one or two battery expansion units (see [Battery expansion unit on page 1-13](#)).

For greater performance and capacity, you can add the following options:

- From 1 to 32 AMS expansion units (see [About AMS expansion units on page 1-11](#)).
- From 1 to 10 AMS high-density expansion units (see [About AMS high-density expansion units on page 1-11](#)).

A minimum of four SATA or SAS drives are required in slots 0 through 3 of the first expansion tray; SSDs are not permitted in these slots.

For more information, refer to the *AMS 2500 Storage System Hardware Guide*.

Table 1-3: AMS 2500 Minimum and Maximum Configurations

Base Unit		Expansion Unit				
SATA/SAS Disk Drives		Type	Units		SATA/SAS Disk Drives	
Minimum	Maximum		Minimum	Maximum	Minimum	Maximum
0	0	Expansion Unit	1	32	1st unit: 4 All other units: 2	15 per unit
		High-Density Expansion Unit	1	10	2 in each section of the unit (see text below)	48 SATA or 38 SAS per expansion unit

Table 1-3: AMS 2500 Minimum and Maximum Configurations

Base Unit		Expansion Unit				
SATA/SAS Disk Drives		Type	Units		SATA/SAS Disk Drives	
Minimum	Maximum		Minimum	Maximum	Minimum	Maximum
Base Unit		Expansion Unit				
SSDs		Type	Units		SSDs	
Minimum	Maximum		Minimum	Maximum	Minimum	Maximum
3	15	Expansion Unit	0	32	First unit: 4 All other units: 2	15 per expansion unit (see text below)
		High-density Expansion Unit	N/A	N/A	N/A	N/A

Minimum supported HDS configuration is two disk drives installed in slots 0 and 1 in side A, and two drives installed in slots 0 and 1 in side B. To locate sides A and B, refer to either:

- The left or right side when facing the front of the unit, or
- The label at the top rear area of the AMS 2500 high-density expansion unit.

The AMS 2500 array supports up to 30 SSDs per system. SSDs can be installed in the expansion unit or intermixed in both the base and expansion units per above minimum and maximum specifications. The minimum number of SSDs supported in a system is three (RAID1+1+spare.) SSDs are not supported as the first five drives in AMS 2500 storage systems.

About AMS expansion units

AMS expansion units are optional for AMS 2100 and AMS 2300 storage systems and required for AMS 2500 storage systems. An AMS expansion unit contains:

- From two to 15 SAS, SATA, or SSD disk drives
- Two redundant power supplies
- Two ENC control units that manage the drives and are used to connect the AMS expansion unit to the base unit and to other AMS expansion units

The number of expansion units supported varies by AMS model:

- An AMS 2100 system supports up to seven expansion units, for a total of 105 drives in the expansion unit, plus an additional 15 drives in the base unit.
- An AMS 2300 system supports up to 15 expansion units, for a total of 225 drives in the expansion unit, plus an additional 15 drives in the base unit.
- An AMS 2500 system supports up to 32 expansion units, for a total of 480 drives.

SATA, SAS, and/or SSD drives can be mixed in an AMS expansion unit. After meeting the minimum number of drives, additional capacity is obtained by installing two drives of the same type (SATA, SAS, or SSD) at a time.

For information about mounting expansion units in a rack, see [Installing AMS high-density expansion units in a rack on page 5-5](#).

About AMS high-density expansion units

AMS high-density expansion units are optional for AMS 2100, AMS 2300, and AMS 2500 storage systems. An AMS high-density expansion unit can contain all SATA drives or all SAS drives. SATA and SAS drives cannot be intermixed in an AMS high-density expansion unit at this time; however, you can intermix 450 GB (when available) and 600 GB SAS drives in an AMS high-density expansion unit that contains only SAS drives. An AMS high-density expansion unit cannot contain SSDs at this time.

An AMS high-density expansion unit contains:

- Either four to 48 SATA disk drives, or four to 38 SAS disk drives.
- Four redundant power supplies
- Four ENC control units that manage the drives and connect to the base unit and to other AMS expansion units

AMS high-density expansion units are sealed, and cannot be configured or serviced by users. To change the configuration for this unit, contact Hitachi Data Systems Technical Support.

For AMS high-density expansion units that contain only SAS drives, the unit's back row (slots HDD_L19 through HDD_L23 on side A slots HDD_R19 through HDD_R23 on side B) cannot be used for SAS drives (see [Figure 1-1](#)).

The number of high-density expansion units supported varies by AMS model:

- An AMS 2100 system supports up to three high-density expansion units, for a total of 159 SATA drives or 129 SAS drives.
- An AMS 2300 system supports up to four high-density expansion units, for a total of 207 SATA drives or 167 SAS drives.
- An AMS 2500 system supports up to 10 high-density expansion units, for a total of 480 SATA drives or 380 SAS drives.



NOTE: Higher SAS HDD counts can be achieved by mixing AMS expansion units and AMS high-density expansion units. Please contact your Hitachi representative for more information.

Preinstallation information for AMS high-density expansion units can be found in [Chapter 5, Preparing for AMS high-density expansion units](#).

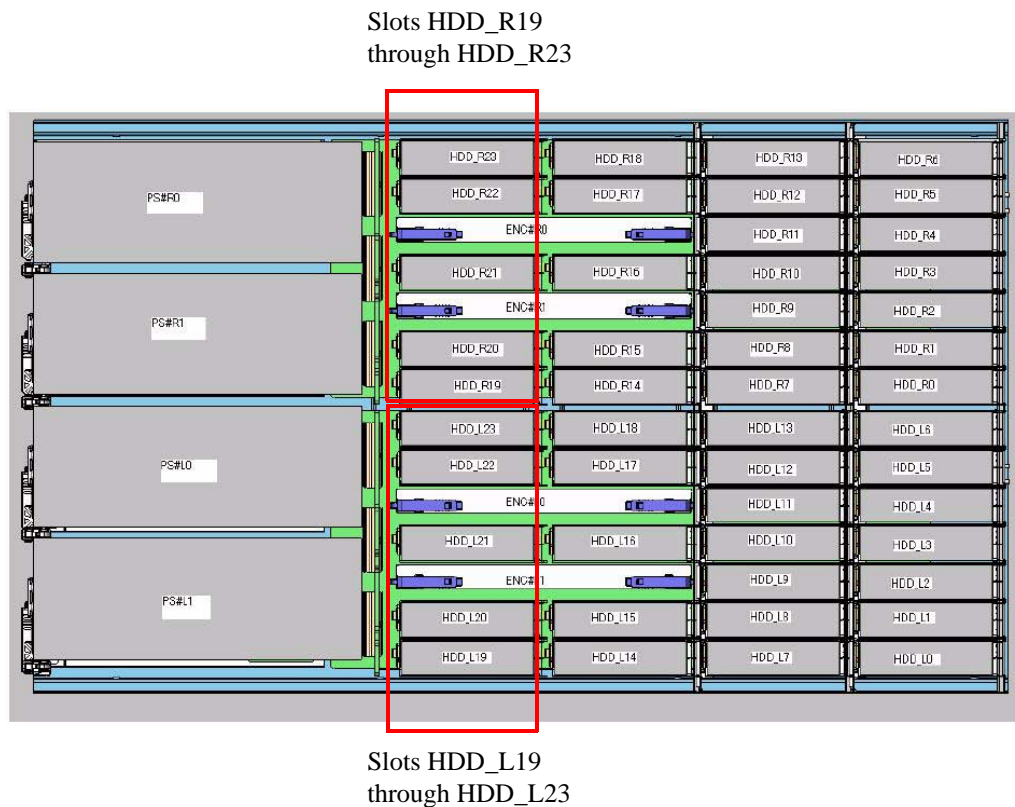

Figure 1-1: AMS High-Density Expansion Unit Drive Slots

Battery expansion unit

Each AMS 2500 is equipped with a battery expansion unit. A battery expansion unit contains its own charger, which is powered by 100/200 VAC. A single battery can connect to both control units. If two batteries are installed, each battery connects separately to a different controller.

Table 1-4 lists the mechanical specifications for the battery expansion unit and Table 1-5 lists the battery expansion unit electrical specifications. These specifications apply to both AC and DC units.

Table 1-4: Battery Expansion Unit Mechanical Specifications (AC and DC)

Item	Specification
Size (W x D x H) inches (mm)	18.9 x 24.5 x 1.7 (479.6 x 623 x 43)
Weight lb. (kg)	approximately 33 (15)
Time to fully charge battery	24 hours or less, depending on the amount of discharge

Table 1-5: Battery Expansion Unit Electrical Specifications (AC and DC)

Item		Specification
AC Input Power Specifications	Input voltage (VAC)	AC 100/200 (89 to 127/178 to 254)
	Steady-state current (A)	1.0/0.5
	Power Consumption (VA/W)	100/100
	Heat value (kJ/h)	360
DC Input Power Specifications	Input voltage (VDC)	-40 to -72
	Steady-state current (A)	1.5
	Power Consumption (VA/W)	72/72
	Heat value (kJ/h)	260

Site preparation responsibilities

The following sections identify the responsibilities of the user and of Hitachi Data Systems when it comes to installing Hitachi AMS 2000 Family storage systems.

User responsibilities

The user is responsible for performing the following tasks, with assistance as needed from the Hitachi Data Systems account team, to prepare for installation of the AMS 2000 Family base, expansion, and high-density expansion units:

- Reading this document carefully to understand installation requirements. You will use the information in this document to determine the specific requirements for your installation.
- Performing the installation planning tasks described in this document.
- Completing the checklist in [Appendix B](#) before equipment delivery to verify that all installation requirements are met. If any requirements are not met, make the changes required to meet the requirements. Be sure to allow enough time to complete the required changes, so that the site is ready when the equipment arrives.
- Providing the customer-supplied hardware that is required for installation and configuration, such as electrical connectors and receptacles (see [User-supplied items on page 4-6](#)).
- Verifying that all installation requirements have been met by completing the Installation Planning Checklist in [Appendix B](#) and that there are no obstructions to getting the AMS 2000 Family base, expansion, and high-density expansion units to their final location (narrow doorways, etc.).
- Observing all applicable safety requirements at all times (see [Chapter 2, Safety](#)).
- Working with your Hitachi Data Systems account team during the installation planning process. This step may include:
 - Providing Hitachi Data Systems with delivery instructions.
 - Unloading the shipping carton.
 - Verifying that neither the carton nor the items in it have been damaged. If items are missing or damaged, should users contact carrier, HDS.
 - Receiving and inspecting the AMS 2000 Family base, expansion, and high-density expansion units.
 - Ensuring that all components on the packing list have been delivered, and that no items are missing.
 - Transporting the units to the installation location (at least 3 people should be used to move and position each unit).

Site/installation coordinator responsibilities

If a site or installation coordinator will be involved, that person should:

- Review the site preparation guide for safety information and system requirements.
- Coordinate personnel and tasks.
- Order required materials.
- Choose the site.
- Review checklists with HDS representative to verify that the site is properly prepared.
- Schedule the installation and personnel for the installation date.
- Ensure that the site is clear of unnecessary material on the installation day.
- Be available throughout the installation.

Facilities personnel responsibilities

If facilities personnel will be involved, those individuals should ensure that installation requirements are met for:

- Space at the installation site
- Temperature and humidity
- Ventilation
- Computer
- Safety and installation materials

In addition, facilities personnel should move the AMS 2000 Family base, expansion, and high-density expansion units in their shipping containers to the installation site before the installation date (at least 3 people should be used to move and position the units) and be available if needed during the installation. Please see [Appendix A](#) for environmental specifications.

Hitachi Data Systems responsibilities

Your Hitachi Data Systems account team will assist you throughout the site planning process. The Hitachi Data Systems account team is responsible for:

- Assisting you as needed to plan the installation for your specific site and operational configuration.
- Coordinating Hitachi Data Systems resources to ensure smooth delivery, installation, and configuration of the units.

Safety

Install Hitachi Adaptable Modular System (AMS) 2000 Family storage systems accordance with the local safety codes and regulations that apply to the facility. This chapter contains additional safety information that may apply to your facility. Read and follow the safety guidelines in this chapter before installing the units. The key sections in this chapter are:

- ❑ [General safety guidelines](#)
- ❑ [Safety symbols](#)
- ❑ [Work safety guidelines](#)
- ❑ [Electrical safety](#)
- ❑ [Electrostatic safety](#)
- ❑ [Warning about moving parts](#)



NOTE: For rack-mount safety precautions, see [Chapter 3, Rack mounting a storage system](#).

General safety guidelines

Observe the following general safety guidelines:

- Do not make mechanical or electrical modifications to the equipment. Hitachi Data Systems is not responsible for regulatory compliance of a modified Hitachi Data Systems product.
- To minimize personal injury in the event of an earthquake, securely fasten the AMS 2000 Family base, expansion, and high-density expansion units to a rigid structure extending from the floor to the ceiling or from the walls of the room in which the units are located.

Safety symbols

Safety warnings, cautions, and instructions in various languages are located on the base, expansion, high-density, and battery expansion units. The safety warnings provide safety guidelines to follow when working with any equipment. We recommend you read all warning labels on the hardware.

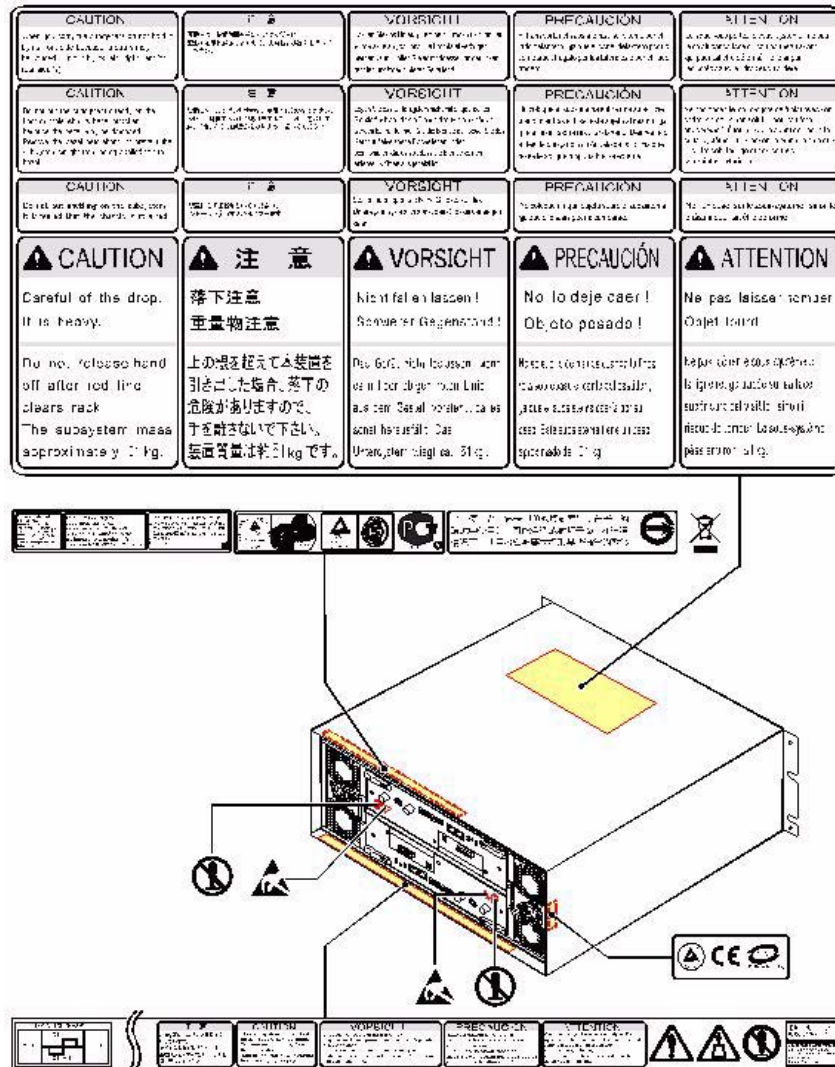

Figure 2-1: Example of Safety Labels on AMS 2100/2300 Base Units

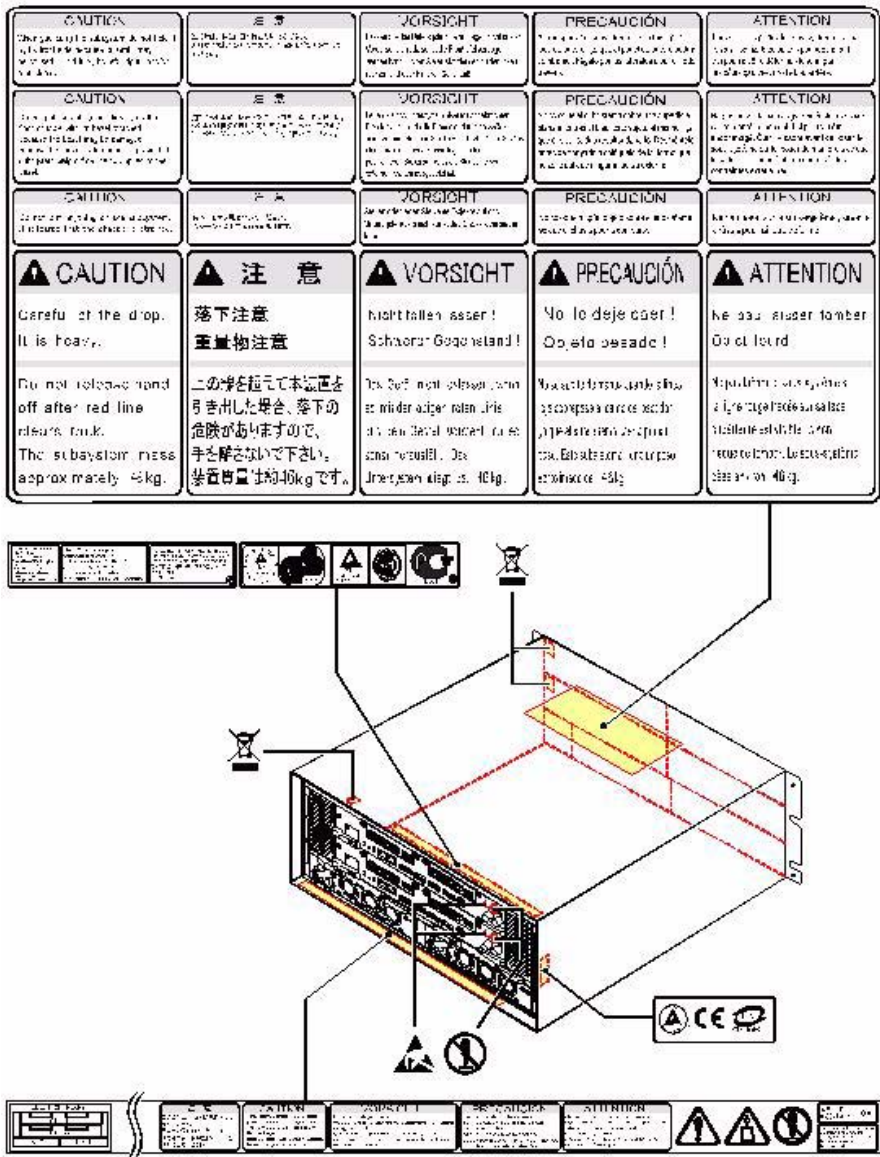

Figure 2-2: Example of Safety Labels on AMS 2500 Base Unit

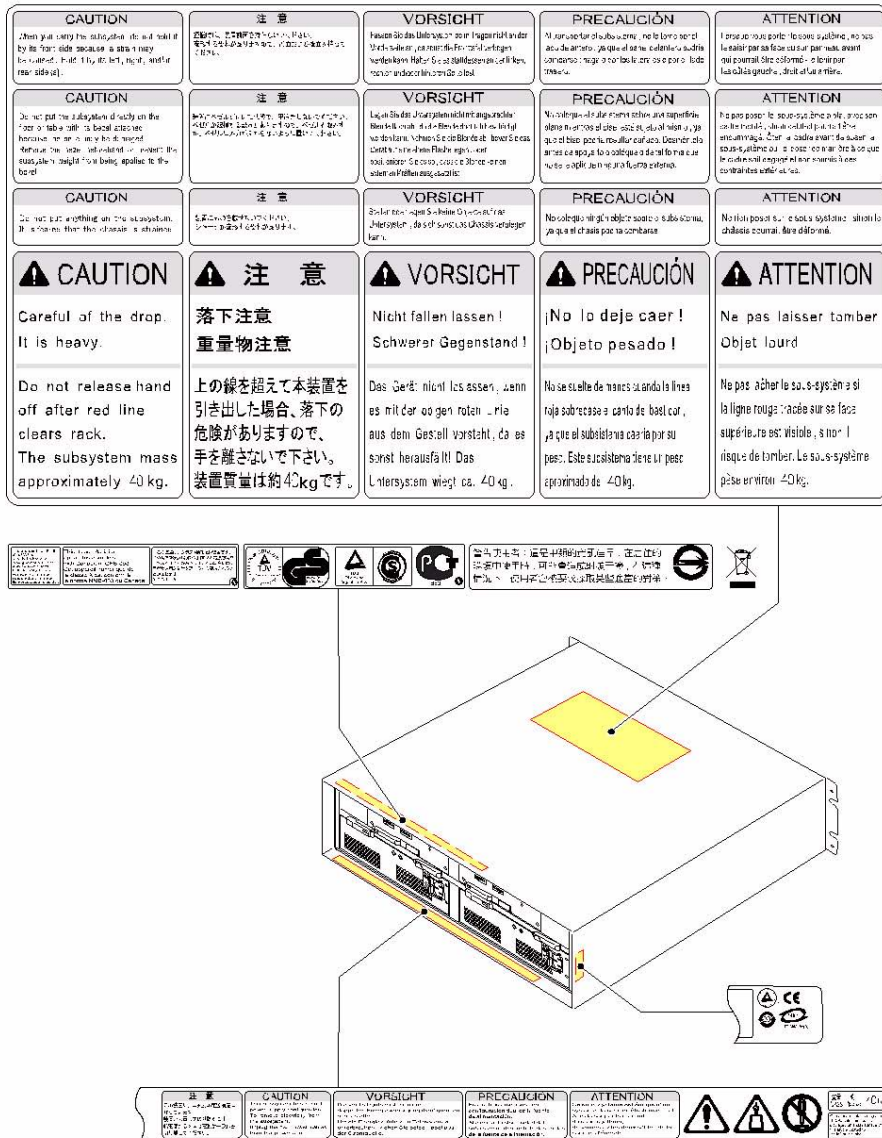

Figure 2-3: Example of Safety Labels on Expansion Unit

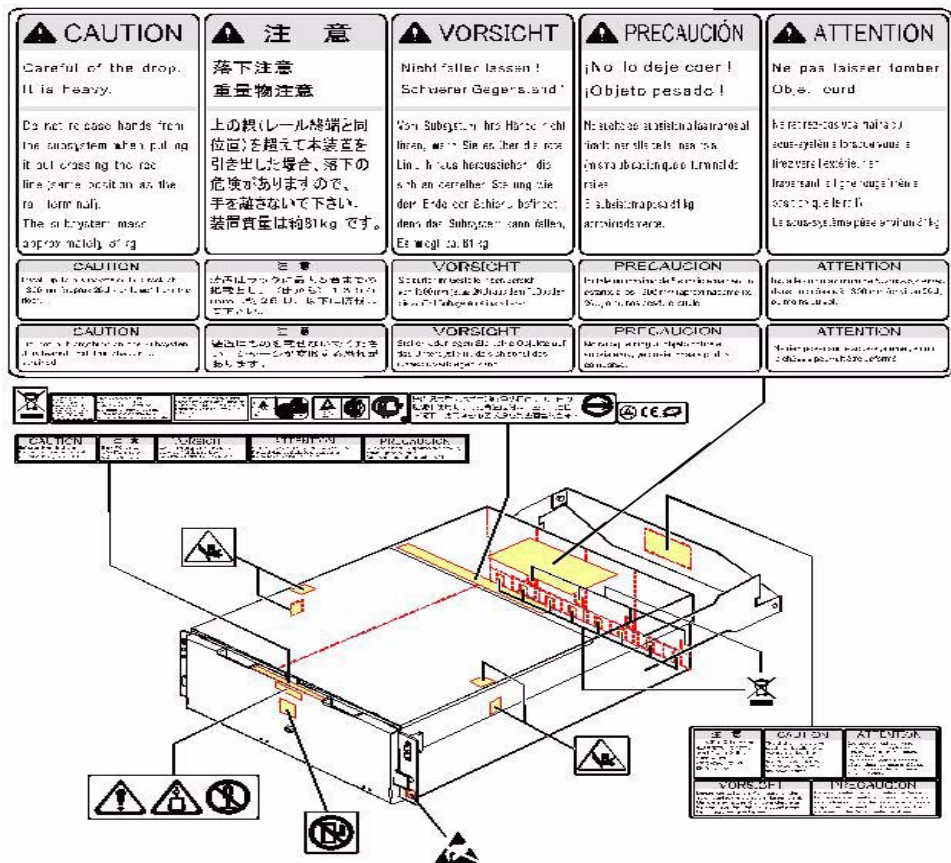

Figure 2-4: Example of Safety Labels on High-density Expansion Unit

Work safety guidelines

Observe the following preventive site guidelines:

- Do not wear loose clothing that could get caught in the chassis or mounting hardware. Fasten your tie or scarf and roll up your sleeves.
- Wear safety glasses when working under conditions that are hazardous to your eyes.
- Do not perform any action that creates a potential hazard to people or makes the equipment or rack unsafe.
- Keep walkways clear of tools, power cables, and parts to prevent them from being stepped on or cause people to trip and fall over them.
- Do not work on the equipment or disconnect cables during a thunderstorm, when wearing a wool sweater or other heavy wool clothing, or when power is applied.
- Keep floors dry to prevent slips and falls.
- Do not use ungrounded power cables.
- Keep the area clear and dust-free during and after installation.
- Do not block or cover the openings of the AMS 2000 Family base, expansion, and high-density expansion units. Never place a unit near a

radiator or heat register. Failure to follow these guidelines can cause overheating and affect the unit's reliability.

- Ensure that the chassis cover is secure. The chassis is designed to allow cooling air to flow effectively within it. An open chassis allows air leaks, which may interrupt and redirect the flow of cooling air from internal components.
- The Hitachi AMS 2000 Family rack is equipped with wheels so that you can move it. Use enough personnel when moving the cabinet, especially on sloping loading docks and ramps, to gain access to a raised computer room floor. Move the cabinet slowly and deliberately, and make sure that the floor is free from foreign objects and cables that the cabinet could roll over.



WARNING! To avoid injury, wear protective footwear when moving AMS 2000 Family base, expansion, and high-density expansion units.

Warning about moving parts

Observe the following warning related to moving parts:

- Tuck in any loose clothing so that it will not be caught by a moving or rotating part such as a fan.
- Tie up long hair.
- Unless otherwise specifically instructed, do not supply power to any device that contains rotating or moving parts that are not properly covered.
- If instructed to supply power to any device with rotating or moving parts whose covers have been removed, work with another person who can immediately turn off the power in an emergency.

Electrical safety

Observe the following safety guidelines:

- Disconnect all power before installation.
- Electrical equipment generates heat. Ambient air temperature might not be adequate to cool equipment to acceptable operating temperatures without adequate circulation. Ensure that the room in which you operate your system has adequate air circulation.
- Ensure that the voltage and frequency of your power source match the voltage and frequency required by the unit.
- All powered equipment should be properly grounded for proper operation and safety. To reduce the risk of electric shock or damage to equipment, follow proper grounding procedures.

Electrostatic safety

Electrostatic discharge (ESD) can damage static-sensitive devices, such as the controllers and drives in the AMS 2000 Family base, expansion, and high-density expansion units. Therefore, observe the following guidelines when handling this equipment:

- Wear an anti-static wrist strap to help prevent damage to the units due to electrostatic discharge (ESD). Connect the clip on the strap to an unpainted part of the chassis to safely channel any static electricity generated by your body to ground. If no wrist strap is available, ground yourself by touching an unpainted part of the chassis.
- When handling a drive, hold it with the hand on which you are wearing the wrist strap. You can discharge static electricity by touching the frame of the drive.
- When installing or removing ESD-sensitive components such as the motherboard, memory, and other printed-circuit boards, place the components on an antistatic mat.

Rack mounting a storage system

This chapter provides guidelines for mounting the Hitachi AMS 2000 Family storage systems in the following racks from Hitachi Data Systems:

- Hitachi AMS 2000 Family racks
- Hitachi Full-Height Solutions racks
- Hitachi AMS 47U rack

This chapter begins with a description of the Hitachi racks, followed by safety, preinstallation, installation, and post-installation instructions that apply to both racks.

The key topics in this chapter include:

- [Overview](#)
- [Hitachi AMS 2000 Family racks](#)
- [Hitachi Full-Height Solutions racks](#)
- [Hitachi AMS 47U rack](#)
- [Safety information](#)
- [Preparing for installation](#)
- [Installing rack equipment](#)
- [Rack-mounting AMS high-density expansion units](#)
- [Post-installation considerations](#)
- [EMEA rack](#)



NOTE: The racks described in this chapter are powered by AC. Hitachi Data Systems also offers DC-powered racks for DC-powered AMS 2500 systems. For more information, see [Chapter 6, DC-powered racks](#).

Overview

Hitachi Data Systems provides two rack models for the AMS 2000 Family storage systems:

- Hitachi AMS 2000 Family racks
- Hitachi Full-Height Solutions racks

The Hitachi AMS 2000 Family racks are designed to hold AMS 2100, AMS 2300, and AMS 2500 storage systems and related components. The Hitachi Full-Height Solutions racks are required for mounting a Hitachi AMS 2500 storage system with AMS 2000 Family high-density expansion units. Alternatively, equivalent racks can be used to hold these Hitachi storage systems if desired, so long as they meet Hitachi Data Systems' specifications (see [Table 3-3 on page 3-9](#) and [Table 3-4 on page 3-13](#)), and, for AMS 2000 Family high-density expansion units, utilize Hitachi-supplied rails.

Hitachi racks are installed at the customer site in one of two configurations:

- In a stand-alone installation, where the rack has sufficient clearance to permanently attach stabilization plates.
- In a bayed installation, where the rack is installed in a row with other racks.

Front stabilizing plates are required for all stand-alone installations. Side stabilization or bayed installations are required when using high-density expansion trays with an AMS 2000 Family storage system. Front stabilizing plates come with the rack, while a side stabilizing plate (7846414) must be ordered separately. All Hitachi Data Systems stabilization plates have anchoring holes. Hitachi Data Systems recommends that stand-alone racks be anchored whenever possible.

All bay-type installations require buying/interconnecting kits (7846415) to attach a rack to an adjacent rack and front stabilizing plates. For more information, see [Securing multiple racks together with the baying kit on page 3-43](#).

Hitachi AMS 2000 Family racks and Hitachi Full-Height Solutions racks are UL listed, with UL labels such as the one in [Figure 3-1](#) applied to the racks.

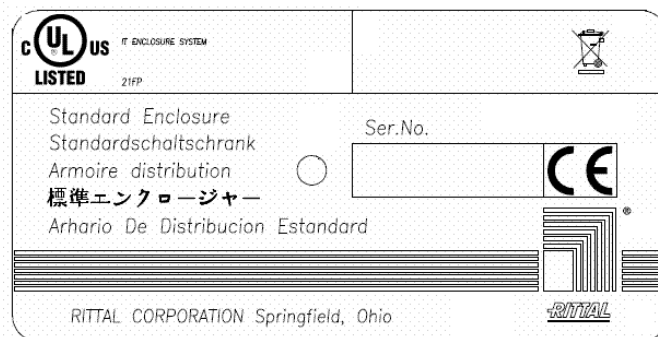

Figure 3-1: Example of UL Label

The following sections provide information about Hitachi AMS 2000 Family Racks (see [page 3-3](#)) and Hitachi Full-Height Solutions racks (see [page 3-10](#)). Guidelines for rack mounting AMS high-density expansion units in a Hitachi Full-Height Solutions rack can be found in [Rack-mounting AMS high-density expansion units on page 3-50](#).

Hitachi AMS 2000 Family racks

Hitachi AMS 2000 Family racks are designed to hold an AMS 2100, AMS 2300, or AMS 2500 storage solution and one or more AMS expansion units. All Hitachi Data Systems AMS 2000 Family racks are 42U high X 1.96 ft (600 mm) wide X 3.45 ft (1050 mm) deep 19-inch cabinets capable of containing all components required for a full installation of the Hitachi Data Systems AMS 2000 Family storage system. [Table 3-1](#) describes the Hitachi AMS 2000 Family racks.

Table 3-1: Hitachi AMS 2000 Family Racks

Product Code	Description
7846630	<p>AMS 2000, Domestic</p> <ul style="list-style-type: none"> • Black Front Bezel/Lock Back Door • External Dimensions (with panels) <ul style="list-style-type: none"> • Width: 1.96 feet (600 mm) • Depth: 3.45 feet (1050 mm) • Height: 6.82 feet (2080 mm) • Fixed rail kits for Hitachi storage • Four 30-amp Nema PDUs, with 32 power cords and accessory kit
7846631	<p>AMS 2000, International</p> <ul style="list-style-type: none"> • Black Front Bezel/Lock Back Door • External Dimensions (with panels) <ul style="list-style-type: none"> • Width: 1.96 feet (600 mm) • Depth: 3.45 feet (1050 mm) • Height: 6.82 feet (2080 mm) • Fixed rail kits for Hitachi storage • Four 32-amp IEC PDUs, with 32 power cords and accessory kit
7846634	<p>AMS 2000, EMEA</p> <ul style="list-style-type: none"> • Black Front Bezel/Lock Back Door • External Dimensions (with panels) <ul style="list-style-type: none"> • Width: 1.96 feet (600 mm) • Depth: 3.45 feet (1050 mm) • Height: 6.82 feet (2080 mm) • Fixed rail kits for Hitachi storage • Four 32-amp IEC PDUs, with 32 power cords and accessory kit

Hitachi Data Systems also offers a third-party Universal Rail Kit 19-inch rack (item code 7846464) for rack mounting devices in third-party racks. Depth is adjustable to facilitate rack mounting. All hardware is included. For more information, see [Using the Universal Rail Kit 19-inch rack-mount rail support kit on page 3-23](#).

Height: 6.82 feet
(2080 mm)

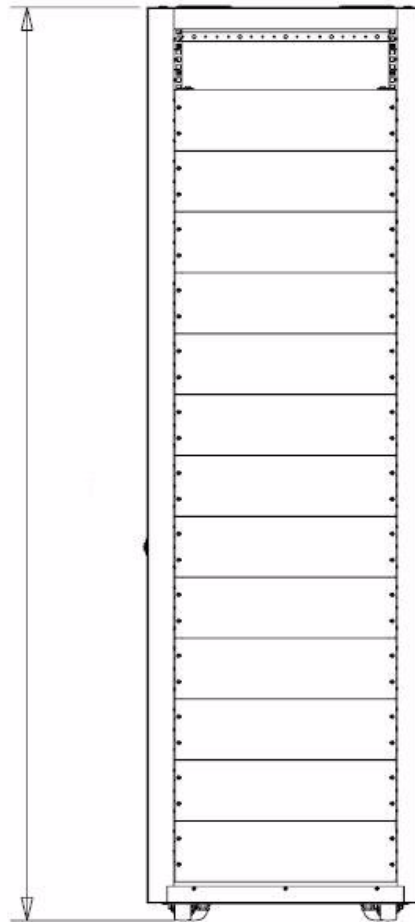

Figure 3-2: Front of the Hitachi AMS 2000 Rack

Depth: 3.45 feet
(1050 mm)

Width: 1.96 feet
(600 mm)

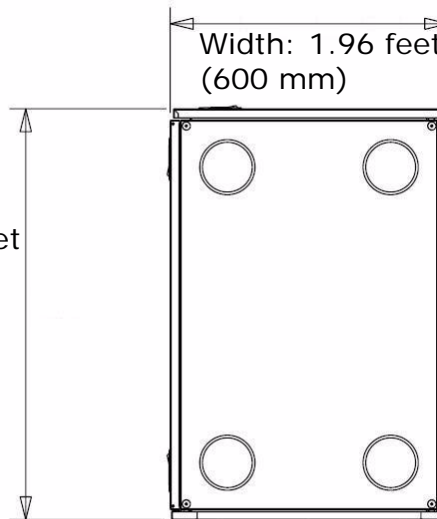

Figure 3-3: Top of the Hitachi AMS 2000 Rack

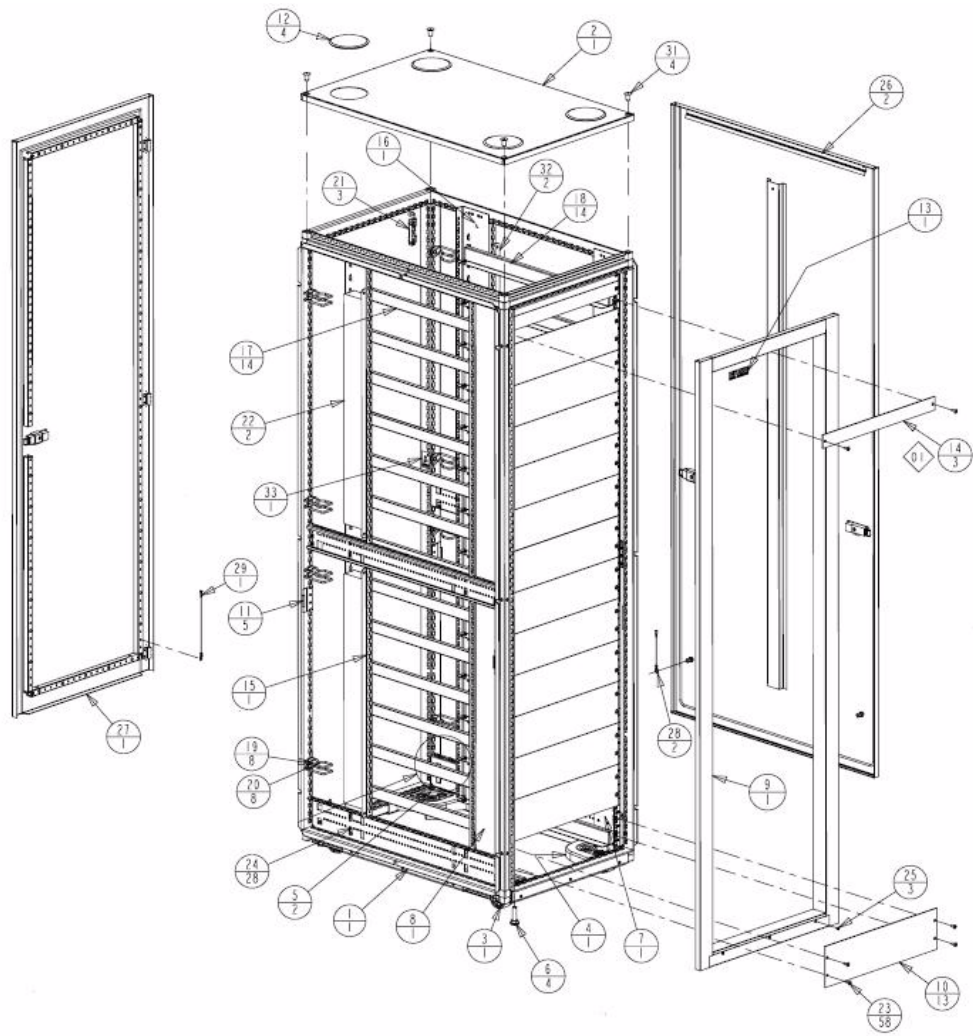

Figure 3-4: Exploded View of the Hitachi AMS 2000 Rack

Installation and maintenance clearance areas

Figure 3-5 shows the installation and maintenance clearance areas for the Hitachi AMS 2000 Family rack. All dimensions in millimeters; dimensions in square brackets (for example, [23.30]) are in inches.

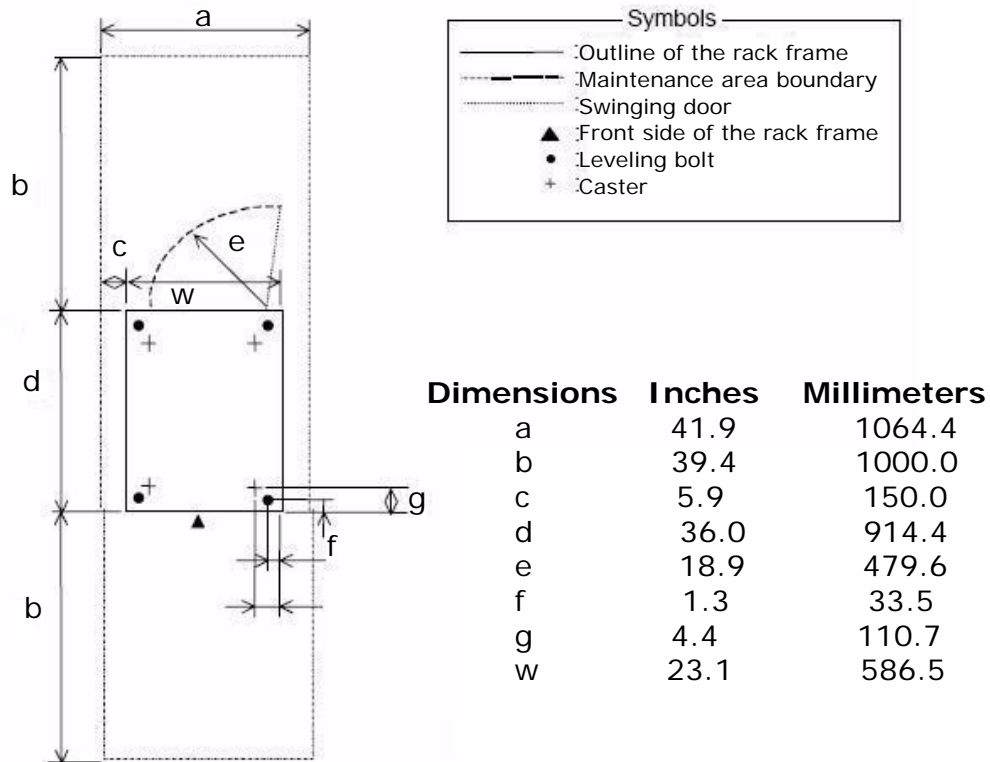

Figure 3-5: Installation and Maintenance Areas

Power

The Hitachi AMS 2000 Family rack is wired for 200-240V with four PDUs.

- **Americas rack (7846630)** comes with four preinstalled 30-amp Nema PDUs and 32 power cords. The PDUs are rated for 200-240VAC, 50/60 Hz, 30 amps, derated to 24 amps.
- **APAC Rack (7846631)** comes with four preinstalled 30-amp IEC PDUs and 32 power cords.

When connecting devices to the PDUs, do not exceed 12 amps per bank of four receptacles, and do not exceed 24 amps per PDU. Follow the guidelines for PDU load as specified in the appropriate Hitachi Data Systems installation documentation.

To ensure maximum system availability, each PDU requires a dedicated 30A circuit. For example, a system with four PDUs, each with a 30A L630P plug, requires four 30A circuits.

If installing third-party components in the rack, identify the component's amperage load and check the current amperage load on the PDUs to determine if the component can be plugged into a PDU.

Hitachi AMS 2000 Family base, expansion, and high-density expansion units have two fully redundant power supplies that provide auto-switching between 110VAC and 230VAC.

To reduce the risk of injury, fire, or damage to persons or equipment, do not exceed the maximum usable amperage per PDU. Consult the electrical authority having jurisdiction over your facility's wiring and installation requirements. When planning for power distribution and requirements for your rack configuration, note the following:

- Balance the amperage load between available PDUs.
- The amperage load on each PDU must not exceed 80% of the PDU current rating (i.e., the maximum amperage is 80% of the 30 amp PDUs, allowing for a maximum of 24 usable amps per PDU).
- If an uninterruptible power supply (UPS) is used, the load should not exceed 80% of the UPS's marked electrical current rating.

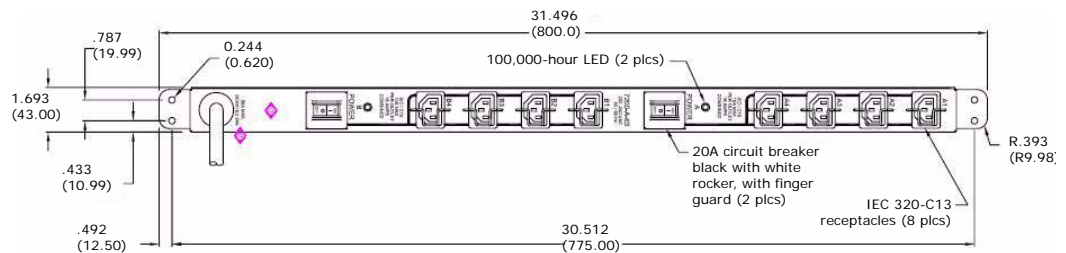

Figure 3-6: Hitachi AMS 2000 Family Rack PDU Design

Floor load rating

In the maximum configuration, the Hitachi AMS 2000 Family storage system can be configured with 1 AMS 2300 and 13 additional units (AMS expansion units with power supplies). The total weight of the system in this maximum configuration is approximately 726 kg (1597.2 lbs).

Types of PDU plugs

Figure 3-7 and Figure 3-8 show the PDU plug types per world region.



Figure 3-7: Plug Type for Canada, United States, and Americas (L6-30P)



Figure 3-8: Plug Type for Asia-Pacific Rack Models (IEC 309)

Power jumper cables

Figure 3-9 shows the power jumper cables (043-100210-01) shipped with the Hitachi AMS 2000 Family racks and Table 3-2 describes the cable. The cable is used to connect AMS 2000 storage systems to the PDU.

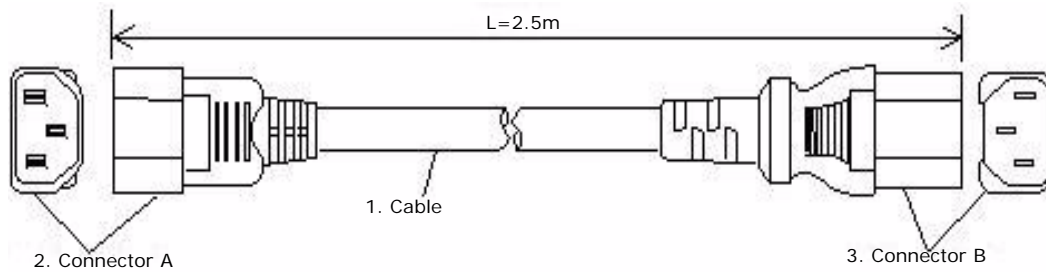

Figure 3-9: Power Jumper Cable (250 VAC 10A IEC320-C14)

Table 3-2: Power Jumper Cable Description
(250 VAC 10A IEC320-C14)

Part Number	Name	Quantity	Model	Applicable Safety Standard / Rating
1	Cable	—	PVC code	UL and CSA
2	Connector A	1	EN60324-C14	For 250 VAC (10 A)
3	Connector B	1	EN60324-C13	For rack frame

Specifications

Table 3-3: Hitachi AMS 2000 Rack Specifications

Item	Specification	Item	Specification
P-code	7846630, 7846631, and 7846634	Frame	Welded steel
Dimensions (HxWxD)	(ft): 6.82 x 1.96 x 3.45 (mm): 2080 x 600 x 1050	Roof	Solid with 4 cable entry holes
Usable Volume (HxWxD)	(ft): 6.12 x 1.6 x 2.63 (mm): 1866 x 488 x 802	Rear Door	Perforated, with lock, ability to optionally mount fans
Weight (approx)	300 lbs / 136 kg	Side Panels	Solid, with locks
Static Weight Capacity*	2000 lbs / 907 kg	Mounting	Four 19" vertical rails, with "U" markings
Power	200-240 VAC (4) 30 amp power strips	Casters	2 fixed in the front 2 swivel casters in the rear
PDU	See Table 3-1 on page 3-3	Dynamic Load	1500 pounds (680.3 kg)
Source Circuit Breaker	Dedicated 30A per PDU	Leveling Feet	4
PDU Source Power Code	Power Cord: Rated 30A, 200-240V APIA Plug: EIC 309 US Plug: L6-30P Length: 9.8 feet (3 meters)	Cable Management	Cable ring guides in the rear
PDU Amperage	30A total 24A usable/derated 12A usable/derated, per 4 outlets 10A max. capability per outlet	Grounding	Black ground straps (door/sides/roof)
Indicator	Green lights (2) when circuit breakers are ON	Blanking Panels	A sufficient number of 3U solid blanking panels to satisfy a configuration
Component Power Cords	Power cord 2 feet, 250V, 15 amps, C14/C13 connector	Support Rails	Rack ships with 14 preinstalled rails
Retainer Clip	8, one per outlet (prevents power cords from being disconnected accidentally)	Front Stabilizer Plate	One "L"-shaped stabilizer plate included with the rack for front use
Temperature	Operating: 0° to 50° C (32° to 122°F) Storage: -25° to 65° C (-13° to 149°F)	Side Stabilizer Plate	Required for stand-alone configurations with high-density expansion unit, (p/n 7846414)
Humidity	0 to 95%, non-condensing	Safety Approvals (rack with power strips)	UL60950 cUL1950 CE
Color	Black	Options	Fan tray (installable in rear door) Shelf Pull-out Shelf Pull-out support rails
Mounting Height in EIA Units	42U	Baying Interconnect Kits	7846415

* Static Weight Capacity refers to the amount of weight the rack can hold with leveling feet. Dynamic Capacity refers to the amount of weight the casters can support when moving the rack.

Hitachi Full-Height Solutions racks

The Hitachi Full-Height Solutions racks can be used to mount a Hitachi AMS 2500 storage system and one or more AMS high-density expansion units. If installing AMS high-density expansion units, see [Rack-mounting AMS high-density expansion units on page 3-50](#) for more information.

Hitachi Full-Height Solutions racks include black lock front and back doors. Its dimensions are 6.56 feet (2001.45 mm) high x 1.96 feet (600 mm) wide x 3.45 feet (1050 mm) deep, with a mounting height of 42U. The rack comes with panels. However, rail kits, PDUs, and power cords with an accessory kit are not included.

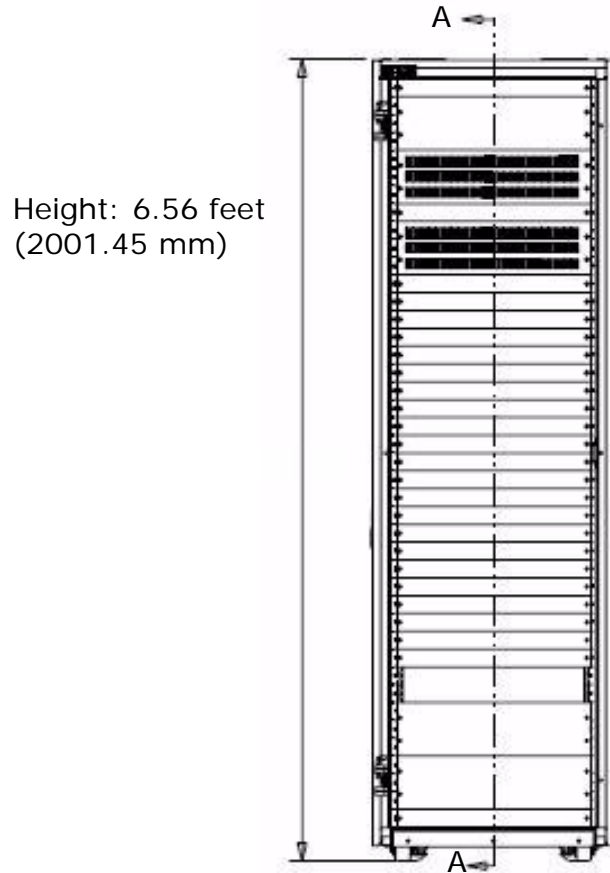

Figure 3-10: Front of the Hitachi Full-Height Solutions Rack (Door Not Shown for Clarity)

Width: 1.97 feet
(601.4 mm)

Depth: 3.43 feet
(1047.08 mm)

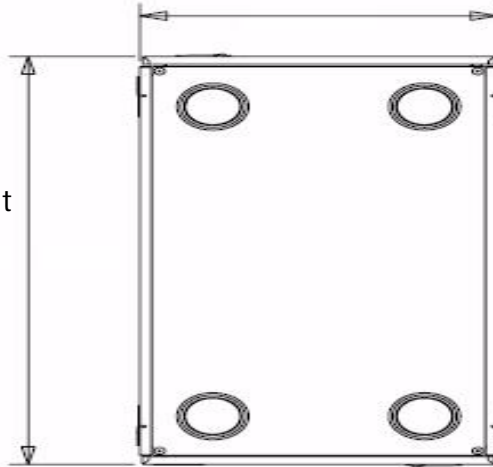

Figure 3-11: Top of the Hitachi Full-Height Solutions Rack

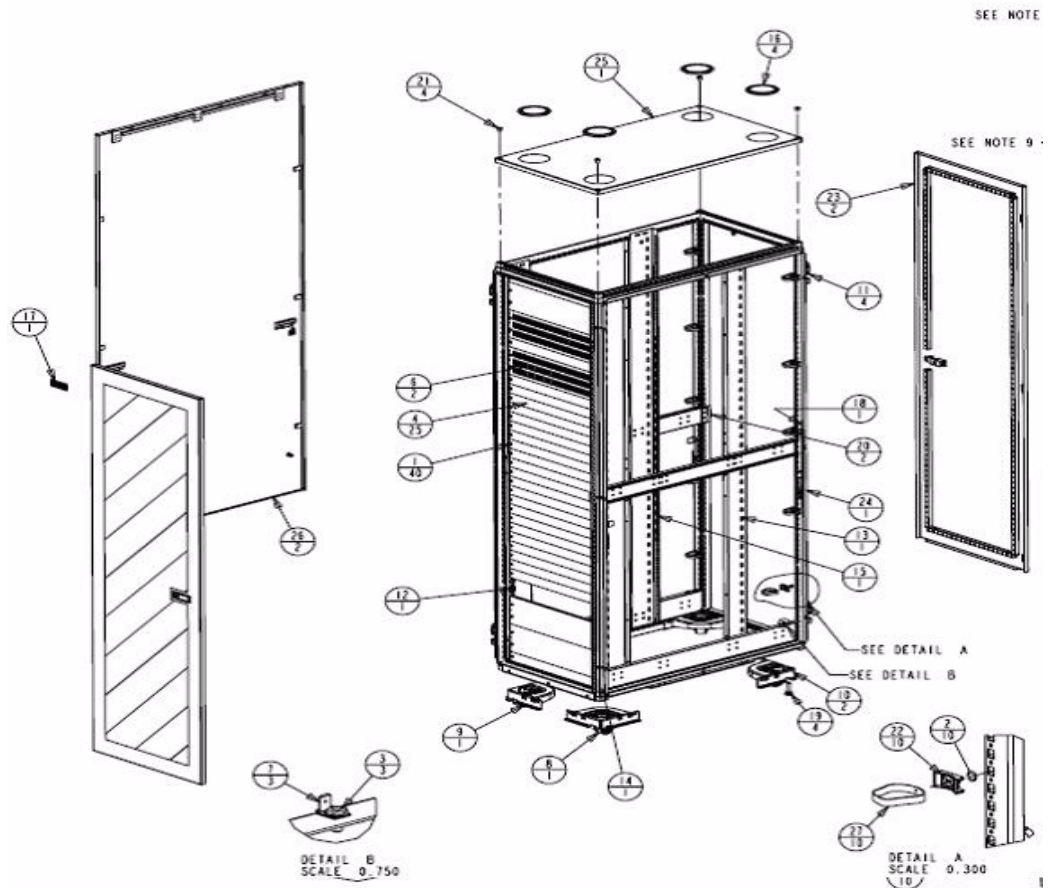

Figure 3-12: Exploded View of the Hitachi Full-Height Solutions Rack

Installation and maintenance clearance areas

Figure 3-13 shows the installation and maintenance clearance areas for the Hitachi AMS 2000 Family rack. All dimensions in millimeters; dimensions in square brackets (for example, [23.30]) are in inches.

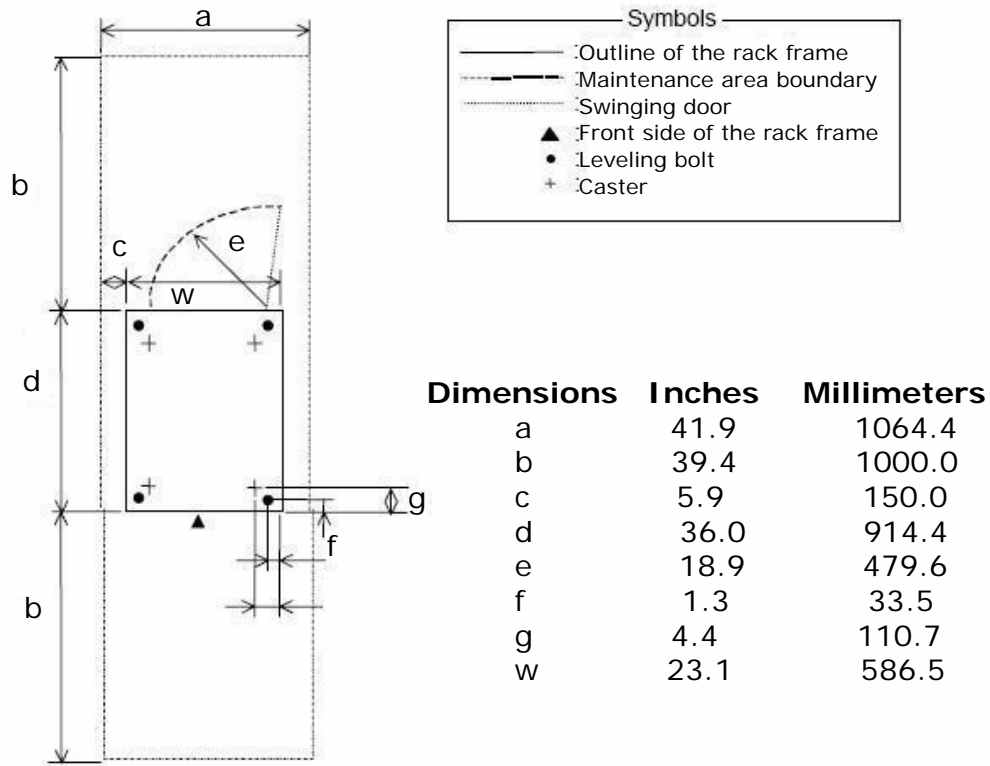

Figure 3-13: Installation and Maintenance Areas

Power

The Hitachi Full-Height Solutions rack is a 220V solution that provides the electrical requirement scalability needed for the AMS 2000 Family storage system. Do not exceed the 24 usable amps to a single PDU.

Floor load rating

In the maximum configuration, the Hitachi AMS 2000 Family storage system can be configured with 1 AMS base unit and up to 13 standard AMS expansion units. The total weight of the system in this maximum configuration is approximately 726 kg (1597.2 lbs). For more information, see [Floor load ratings on page 4-3](#).

Specifications

Table 3-4: Hitachi Full-Height Solutions Rack Specifications

Item	Specification	Item	Specification
P-code	7846450	Front Door	Perforated, with lock, black
Dimensions (HxWxD)	6.56 x 1.97 ft x 3.45 ft 42U x 601.4 mm x 1050 mm	Rear Door	Perforated, with lock, ability to optionally mount fans, black
Usable Volume (HxWxD)	6.12 x 1.6 x 2.63 ft 1866 x 488 x 802 mm	Side Panels	Solid, with locks
Weight (approx)	341 lbs / 155 kg	Mounting	Four 19" vertical rails, with "U" markings
Static Weight Capacity*	2000 lbs / 907 kg	Casters	2 fixed in the front 2 swivel casters in the rear Each caster rated at 249 kg (550 lbs) each (dynamic capacity) *
Power	Depends on separately ordered PDU (see Table 3-5 on page 3-14)	Dynamic Load	1500 pounds (680.3 kg)
PDU	Ordered separately (see Table 3-5 on page 3-14)	Leveling Feet	4
Component Power Cords	Not included	Cable Management	Cable ring guides in the rear
Indicator	Green lights (2) when circuit breakers are ON	Grounding	Black ground straps (door/sides/roof)
PDU Source Power Cord	Ordered separately (see Table 3-5 on page 3-14)	Blanking Panels	A sufficient number of 3U solid blanking panels to satisfy a configuration
Temperature	Operating: 0° to 50° C (32° to 122°F) Storage: -25° to 65° C (-13° to 149°F)	Support Rails	None
Humidity	0 to 95%, non-condensing	Front Stabilizer Plate	One "L"-shaped stabilizer plates included for front use
Color	Black	Side Stabilizer Plate	Required for stand-alone configurations with high-density expansion unit, (p/n 7846414)
Mounting Height in EIA Units	42U	Safety Approvals (rack with power strips)	UL60950 cUL1950 CE
Frame	Welded steel	Options	Fan tray (installable in rear door) Shelf Pull-out Shelf Pull-out support rails
Roof	Solid with 4 cable entry holes	Baying Interconnect Kits	7846415

* Static Weight Capacity refers to the amount of weight the rack can hold with leveling feet. Dynamic Load refers to the amount of weight the casters can support when moving the rack.

Table 3-5: Solutions Rack PDU

Item	America	International
P-code	7846466	7846467
Input Characteristics		
Voltage	200 - 250VAC	200 - 250VAC
Frequency	50/60 Hz	50/60 Hz
Line Current	30A Max	32A Max
Load Capacity	6.90 KVA	7.36KVA
Overload Protection: Circuit Breaker	(2) 2P/15A UL489	(2) 2P/16A UL489
Power Cord: 10' (3m), #10AWG/3C	Yes	Yes
Connector	NEMA L6-30P	56P332 Plug
Indicators: Power-on, LED	Yes	Yes
Output Characteristics		
Voltage	200 - 250VAC	200 - 250VAC
Current (Total Combined Load)	30A	30A
Outlets: 2x 12 IEC C13	Yes	Yes
Mechanical Characteristics		
Material: CRS	Yes	Yes
Finish: Powder Coat, Black, Fine Texture	Yes	Yes
Lettering: Silk-Screen, White/Epoxy	Yes	Yes
Storage Temp.: -13° to 149°F (-25° to 65°C)	Yes	Yes
Operating Environment		
Temperature: 32° to 122°F (0° to 50°C)	Yes	Yes
Relative Humidity: 0 - 95% (non-condensing)	Yes	Yes
Elevation: 0 - 10,000FT (0 - 3000 m)	Yes	Yes
Regulatory Conformance		
Safety Agency: UL/cUL, UL60950-1, CE	Yes	Yes
RoHS: Compliant to Directive 2002/95/EC	Yes	Yes

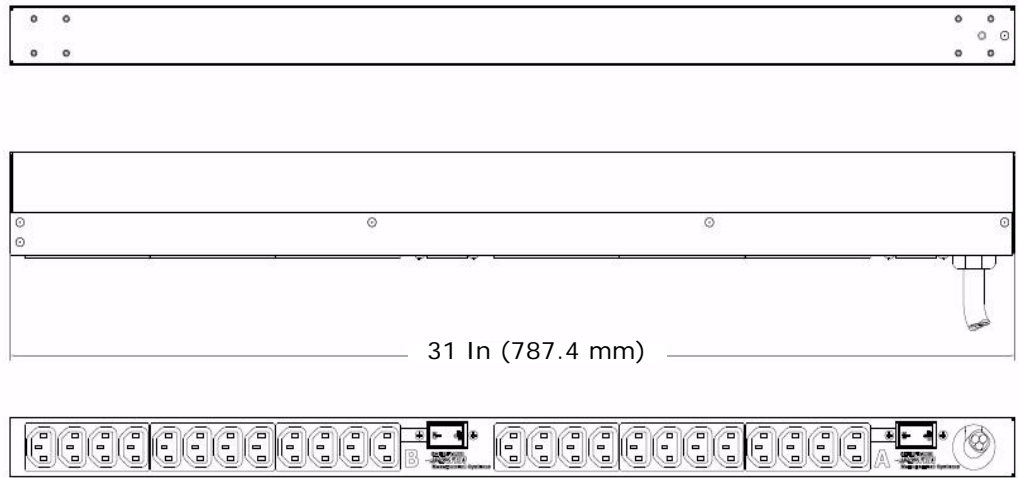

IEC309-32A



L6-30P PLUG END

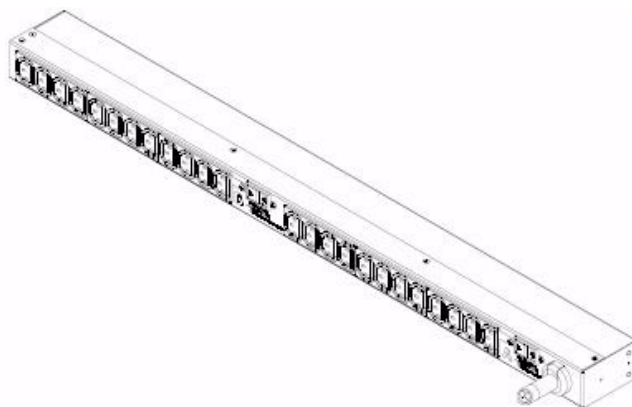
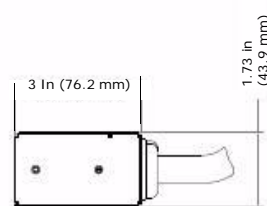
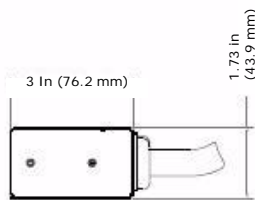

Figure 3-14: Full-Height Solutions Rack PDU

Hitachi AMS 47U rack

The Hitachi AMS 47U rack is a 47U rack that can accommodate up to 10 AMS expansion units with 480 disk drives in a single rack. This rack is an alternative solution to customers who have the capability for delivery, installation, and maintenance.

The following delivery, installation, and maintenance requirements are mandatory for this rack:

- **Delivery.** The customer's loading dock, elevators, ceilings, passageways, and so on must be tall enough to allow for the rack's additional height. Any transportation you perform must also take this into consideration.
- **Installation and maintenance.** Customers must have personnel who are experienced in the safety and handling issues associated with extra tall racks and any equipment needed to facilitate their use. This includes:
 - An appropriate lift that can handle 200+ lbs and service 47U
 - Installation of baying and stabilizing kits
 - Step ladders
 - Sufficient clearance of floor space
 - Methods of securing the rack to the ceiling or floor

The Hitachi AMS 47U rack include black lock front and back doors. Its dimensions are 88.13 inches (2238.6 mm) high x 23.5 inches (597 mm) wide x 41.513 inches (1054.43 mm) deep, with a mounting height of 47U. The rack comes with panels. However, rail kits, PDUs, and power cords with an accessory kit are not included.

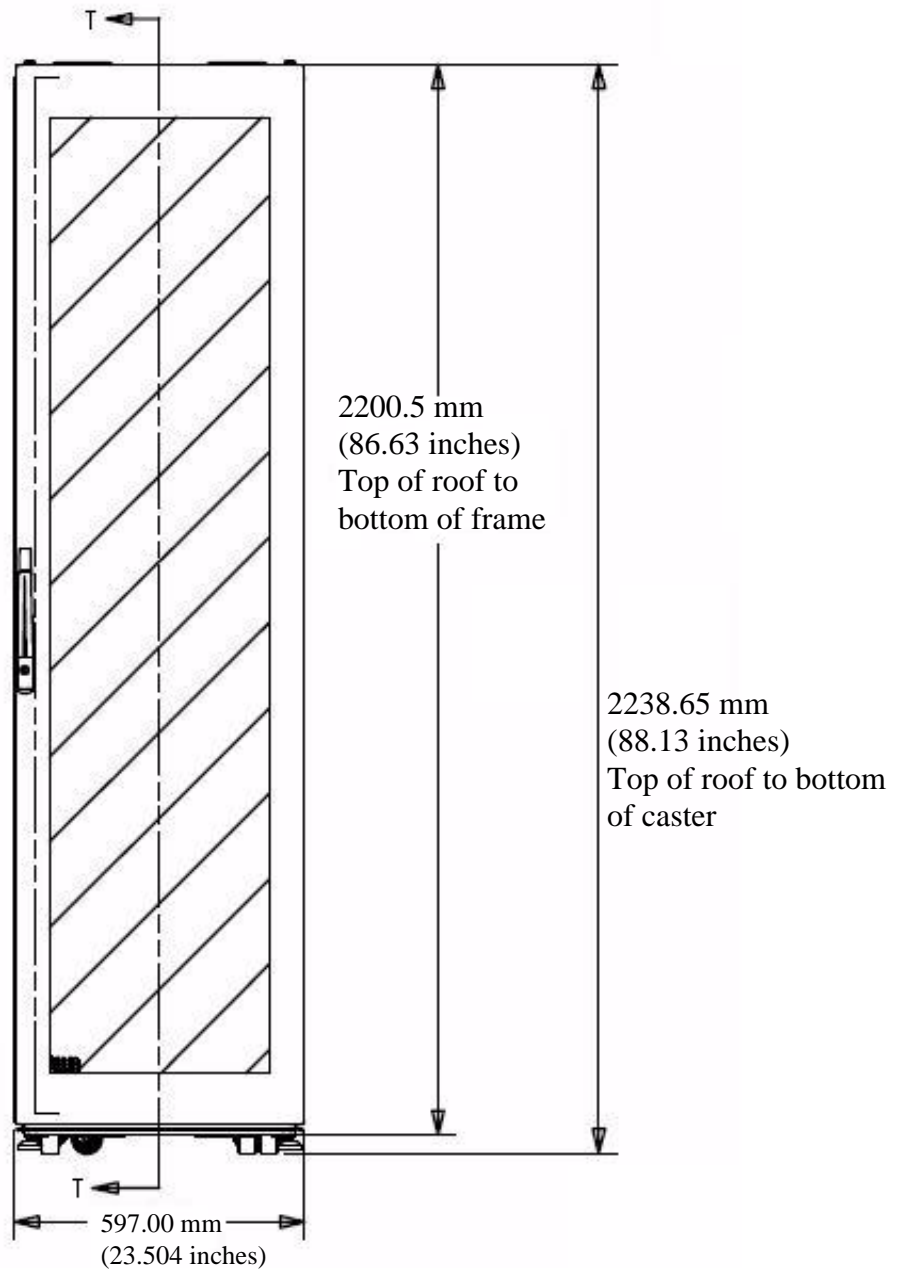

Figure 3-15: Front View of Hitachi AMS 47U Rack

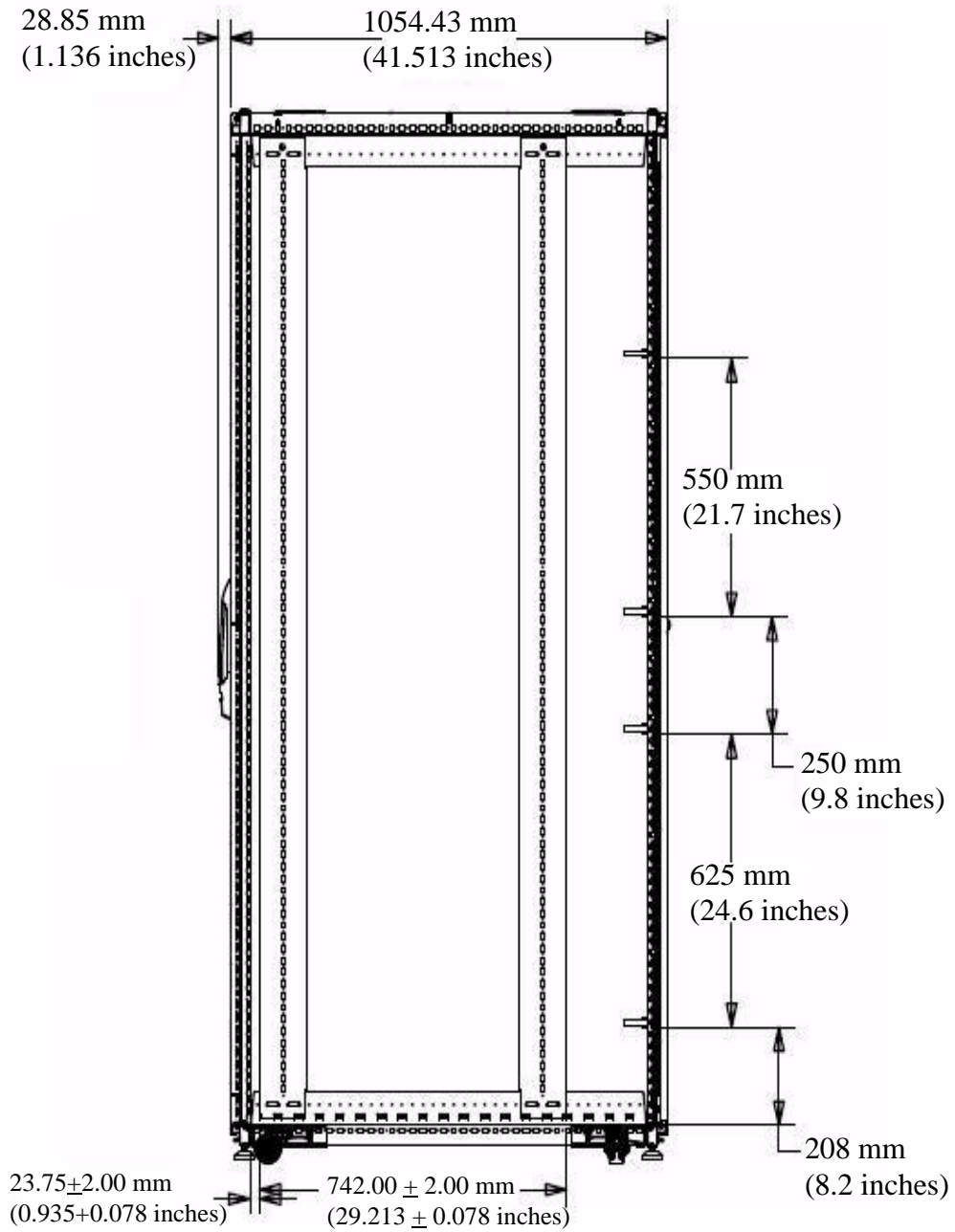

Figure 3-16: Side View of Hitachi AMS 47U Rack

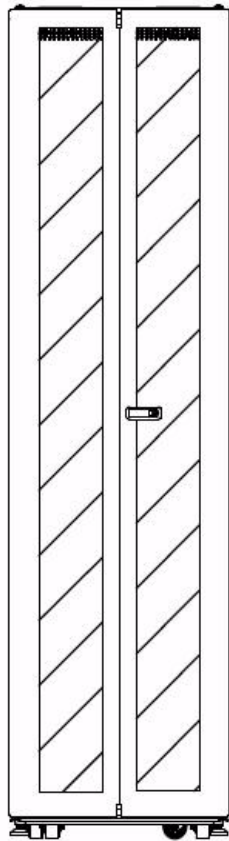

Figure 3-17: Rear View of Hitachi AMS 47U Rack

Specifications

Table 3-6: Hitachi AMS 47U Rack Specifications

Item	Specification	Item	Specification
P-code	7846475	Front Door	Perforated, with lock, black
Dimensions (HxWxD)	88.13 x 23.5 x 41.513 inches 2238.6 x 597 x 1054.43 mm	Rear Door	Split with Master/Slave, Lock
Usable Volume (HxWxD)	6.85 x 1.6 x 2.63 feet 2088 x 488 x 802 mm	Side Panels	Solid, with screws
Weight (approx)	410 lbs / 186 kg	Mounting	Four 19" vertical rails, with "U" markings
Static Weight Capacity*	3200 lbs / 1451 kg	Casters	2 fixed in the front 2 swivel casters in the rear Each caster rated at 249 kg (550 lbs) each (dynamic capacity)*
Power	208VAC, 3 Phase Delta, (2) 60 Amp PDUs	Dynamic Load	2250 lbs / 1021 kg
PDU	Power Cord: Rated 60A, 208V, 50/60Hz	Leveling Feet	4
Component Power Cords	Power cord 2 feet, 250V, 15 amps, C14/C13 connector	Cable Management	Cable ring guides in the rear
Indicator		Grounding	Black ground straps (door/sides/roof)
PDU Source Power Cord	10' (3m) (8G/4C) 3W+PE	Blanking Panels	A sufficient number of 3U solid blanking panels to satisfy a configuration
Temperature	32° to 122°F (0° to 50°C)	Support Rails	None
Humidity	0 – 95%, non-condensing	Front Stabilizer Plate	One "L" shaped stabilizer plate included with the rack for front use
Color	Black	Side Stabilizer Plate	Required for stand-alone configurations
Mounting Height in EIA Units	47U	Safety Approvals (rack with power strips)	UL/cUL UL60950-1
Frame	Welded steel	Options	Temperature and humidity probe
Roof	Solid with 4 cable entry holes	Baying Interconnect Kits	8800490

* Static Weight Capacity refers to the amount of weight the rack can hold with leveling feet. Dynamic Load refers to the amount of weight the casters can support when moving the rack.

Table 3-7: Hitachi AMS 47U Rack PDU

Item	America
P-code	7846475
Input Characteristics	
Voltage	208VAC, 3 Phase Delta
Frequency	50/60 Hz
Line Current	60A Max
Phase Current	34.6A
Load Capacity	21.6 KVA
Overload Protection: Circuit Breaker	2P/15A x9 UL489
Power Cord: 10' (3m), (8G/4C) 3W+PE	Yes
Connector	IEC309 60A PIN and sleeve
Indicators: Power-on, LED	Yes
Output Characteristics	
Voltage	208VAC
Current	12A per outlet 12A per breaker group (derated for North America)
Outlets	C13 x 22
Mechanical Characteristics	
Material: CRS/G40	Yes
Finish: Powder Coat, Black, Fine Texture	Yes
Lettering: Silk-Screen, White/Epoxy	Yes
Storage Temp.: -25° to 149°F (-25° to 65°C)	Yes
Operating Environment	
Temperature: 32° to 122°F (0° to 50°C)	Yes
Relative Humidity: 0 - 95% (non-condensing)	Yes
Elevation: 0 - 10,000FT (0 - 3000 m)	Yes
Regulatory Conformance	
Safety Agency: UL/cUL, UL60950-1	Yes
RoHS: Compliant to Directive 2002/95/EC	Yes

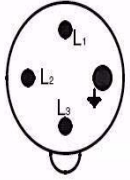

IEC 309 60A Pin and Sleeve Connector

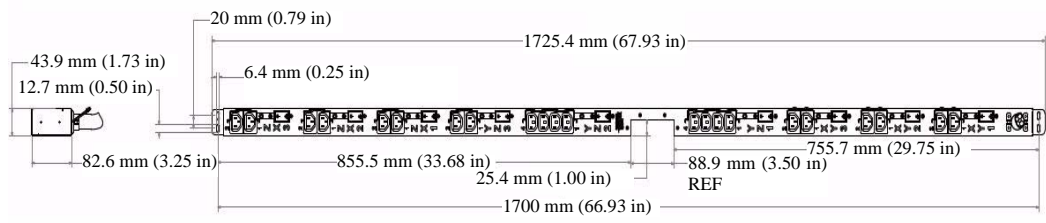
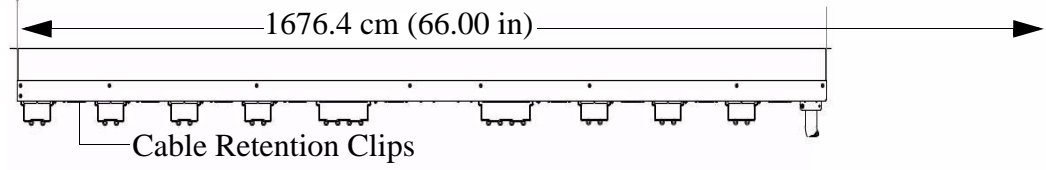

Using the Universal Rail Kit 19-inch rack-mount rail support kit

Hitachi Data Systems also offers a third-party Universal Rail Kit 19-inch rack-mount rail support kit (item code 7846464) for rack mounting devices in third-party racks.

The contents of the kit are:

- Inner rail assembly left
- Inner rail assembly right
- Four M5 flat-head screws
- Four M5 caged nuts

The kit offers the following adjustability and load-bearing limit:

- Minimum depth adjustability: 23.8 inches (606 mm)
- Maximum depth adjustability: 33.1 inches (842 mm)
- Load-bearing limit: 150 lbs (68 kg)

The following procedure describes how to install the Universal Rail Kit 19-inch rack-mount rail support kit (see [Figure 3-18 on page 3-24](#)).

1. Install the first inner rail assembly (either the left or right):
 - a. Loosen the hex nuts at the rear of the support rail kit to adjust for the depth of the storage solution to be rack mounted.
 - b. Orient and insert the caged nuts into the square EIA rail flanges (one front and one rear per side).
 - c. Align the support rail flange holes with the caged nuts and install the front screw to secure the assembly in place.
 - d. Install the M5 screw at the rear of the cabinet and tighten to the following torque: 1.0 N•m, 8.85 in•lbs. If a torque wrench is not available, tighten the screw to hold the rail firmly in place. Be careful not to overtighten.
 - e. Install another M5 screw at the front of the cabinet and tighten to the following torque: 8.85 in•lbs.
2. Repeat the previous step to install the rail kit on the opposite side.

[Figure 3-19 on page 3-25](#) shows various views of the installed rack-mount rail support installation kit.

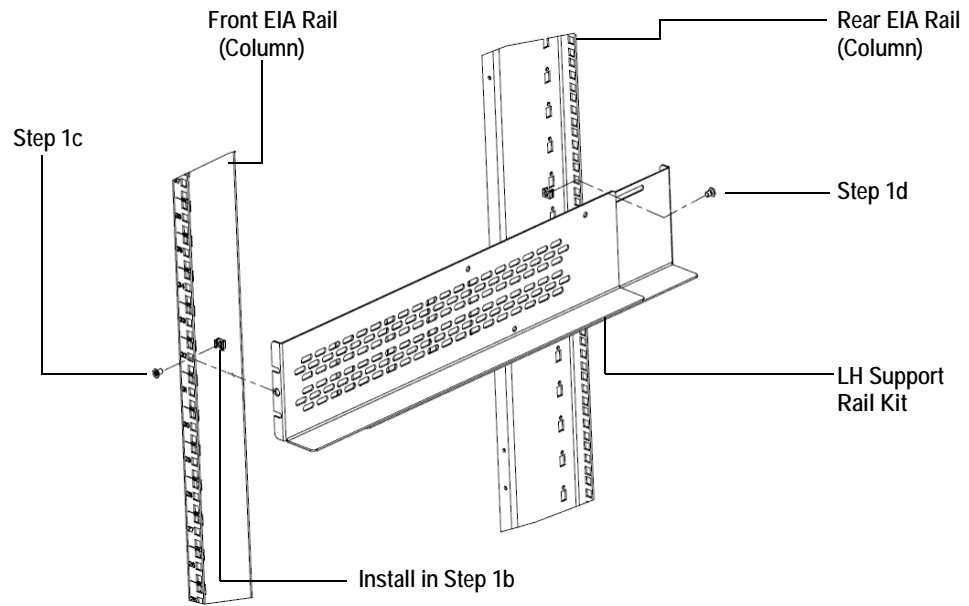
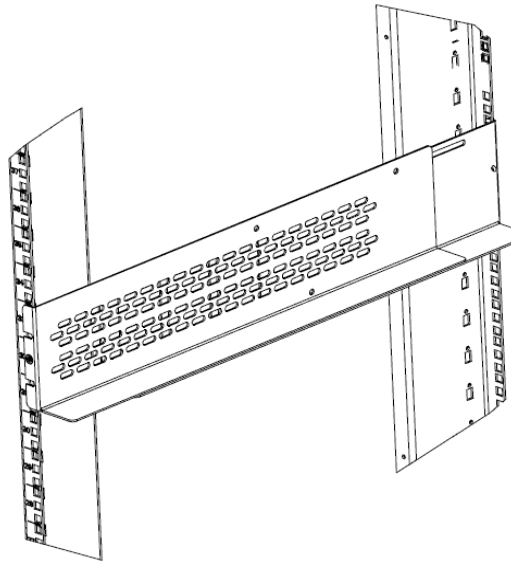
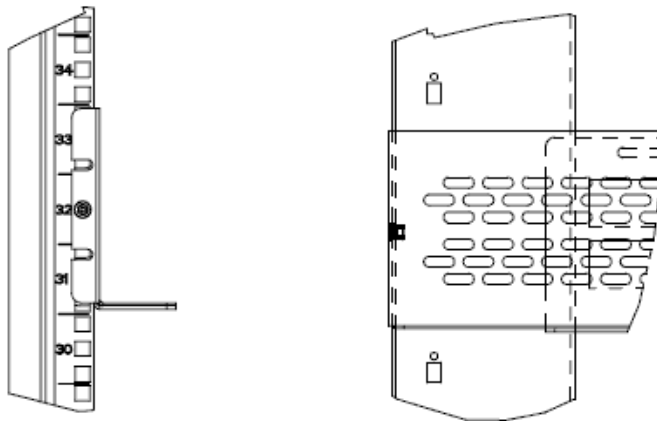

Figure 3-18: Installing the Rack-Mount Rail Kit Rail Assembly, Left Side Shown



Rail Assembly



Front View After Installation

Side View (Hidden Lines Shown)

Figure 3-19: Views of the Rack-Mount Rail Support Installation Kit

Safety information

The following safety information applies to the Hitachi Full-Height Solutions rack or Hitachi Full-Height Solutions rack. Please read and follow the safety guidelines and procedures in this section as well as in the manuals for any products you install in the racks before installing any components in the racks.

The following hazard warnings are provided in this section and on rack-mounted products to prevent or reduce the risk of personal injury and product damage.

- **Danger** indicates an imminently hazardous situation which, if not avoided, may result in death or serious injury.
- **Warning** indicates an imminently hazardous situation which, if not avoided, may result in death or serious injury.
- **Caution** indicates a potentially hazardous situation which, if not avoided, may result in injury or damage to product.

Observing safety guidelines

Observe the following safety guidelines.

- If you notice unusual heat generation, odors, or smoke emission, shut off the power feed to the equipment and contact a maintenance engineer. Leaving such conditions unattended may result in hazardous physical conditions and equipment failure.
- Avoid physical disruption to the equipment. This may result in hazardous physical conditions and equipment failure.
- Avoid using the equipment for any use other than its original purpose; otherwise, an injury or equipment failure may result.
- If using a lift, do not move it away from the rack frame or lower the platform until the component you are mounting is fully inserted into the rack. Otherwise, the component may fall.
- If warning labels become dirty or start peeling off, replace them.



WARNING! The rack allows many components to be mounted vertically. The weight and location of the components in the rack must be planned to place the center of mass as much as possible below the mid-point of the rack. To reduce the risk of danger to persons or equipment, please follow the safety guidelines and stabilize the rack as described in this chapter.

If installing a single (stand-alone) rack, be sure the rack is level and has been stabilized before installing the components. If an unstable rack is loaded with components, it may become unbalanced and tip over.

Preventing electric shock

To prevent electric shock, observe the following guidelines.



WARNING! In case of electric shock, remain calm, and take immediate and appropriate action according to your company's first-aid and safety procedures.

- Before starting work, be sure there are no potential electric hazards in the maintenance area such as insufficient grounding or a wet floor.
- Before starting work, note where the emergency power-off switches are located, and be sure you know how to operate them.
- Unless otherwise specifically instructed, cut off all power sources to the rack or the rack-mounted components before starting maintenance. Just switching off the rack-mounted components is usually not enough. When power is fed from a wall or floor outlet, unplug the power supply cord, or turn off the switch on the power distribution panel or board.
- Attach a notice on the panel or board prohibiting the use of the switch. If the rack-mounted components have already had their power turned off, be sure these conditions are satisfied.
- Do not touch any uninsulated conductor or surface which may remain charged for a limited time after the external power supply to a rack-mounted component is disconnected.
- If working on a rack-mounted component that has a grounding terminal, be sure the terminal is properly connected to the facility's ground.
- If working near a hazardously energized part, do not work alone. Work with another person who can immediately turn off the power in an emergency.
- Do not wear any metallic item such as a wristwatch with a metallic surface or metallic accessories. If you wear eyeglasses with a metallic frame, do not allow the frame to touch an uninsulated surface.
- Be sure your hands and arms are dry.
- Unless otherwise specifically instructed, use only one hand when it is necessary to work near an exposed live electric circuit. This prevents the completion of the circuit through both hands even if you accidentally touch the circuit.
- Do not use a dental mirror near an exposed live electric circuit. The mirror surface is conductive and can become hazardous even if it is made of plastic.
- Unless otherwise specifically instructed, do not supply power to any subassembly such as a power supply unit or a motor while it is removed from its main product.

Preventing electrostatic discharge

To prevent damage to equipment mounted in the rack, take necessary precautions during maintenance activities (storage, switches, PDU, etc.). A discharge of static electricity from a finger or other conductor may damage system boards or other static-sensitive devices.

Follow the recommended handling procedures that accompany the equipment you are mounting or handling.

Use one of the following methods for grounding when handling or installing electrostatic-sensitive parts in the rack:

- Use a wrist strap connected by a ground cord to the grounded aluminum bar or to the chassis of mounted equipment that is grounded. For proper grounding, wear the strap snug against the skin.
- If you do not have any of the suggested equipment for proper grounding, have Hitachi Data Systems technical support install the part.

Fire

Shut off all the power to the machine using the emergency power-off switch. If the fire continues to burn after power is shut off, take suitable actions immediately, such as using a fire extinguisher and calling the fire department.

Working around rotating or moving parts

Observe the following precautions when working around rotating or moving parts.

- Tuck in your tie, scarf, shirt, or any other loose clothing so that it will not be caught by a rotating or moving part.
- Tie up long hair.
- Unless otherwise specifically instructed, do not supply power to any device with rotating or moving parts that are not properly covered.
- When instructed to supply power to any device with rotating or moving parts whose covers have been removed, work with another person who can immediately turn off the power in an emergency.

Be aware of all potential hazards

It is not possible to describe every hazard that may exist with this equipment. Be aware of all possible hazards, and work safely.

Precautions when using the rack-mounted equipment

This section explains precautions for:

- Casters — see [page 3-29](#)
- Rack stability — see [page 3-29](#)
- Weight and location considerations — see [page 3-29](#)
- Height considerations — see [page 3-31](#)
- Placing components in the rack — see [page 3-31](#)
- Working with racks or components — see [page 3-32](#)
- Air vents and airflow — see [page 3-33](#)
- Blanking panels — see [page 3-33](#)
- Cable Guidelines — see [page 3-33](#)

Casters

Hitachi racks have casters that facilitate movement of the rack across short distances to position it for final installation. Although the casters can support the weight of the rack with installed components, they are not designed for supporting the full weight of the rack on a long-term basis. As soon as the rack is in its final position for installation, be sure the full weight of the rack is supported by the stabilizing feet; otherwise, the casters may be damaged.

Rack stability

To reduce the risk of injury to persons or equipment, observe the following guidelines:

- Stabilize the rack frame on-site by adjusting the leveling feet.
- The full weight of the rack should be resting on the levelers, not on the casters.
- Be sure the front anti-tip stabilizing plate is installed before extending any equipment to the front (see [Stabilizing the rack on page 3-38](#) and [Installing side stabilizer plates on page 3-41](#)). Using anti-tip stabilizing plates installed at the bottom left and right sides increases rack stability.
- If extending equipment out of the rack, extend only one tray at a time. Extending two or more at a time may cause the rack to be unstable and pose unnecessary risk or danger.
- Always follow common sense and safety precautions.

Weight and location considerations

The Hitachi racks allow many components to be mounted vertically. The weight and location of the components in the rack must be planned to ensure that the center of mass is as much as possible below the mid-point

of the rack. To reduce the risk of danger to persons or equipment, please follow the safety guidelines and stabilize the rack as described in this manual.

- For single (stand-alone) racks, be sure the rack is level and has been stabilized before installing components. If an unstable rack is loaded with components, it may become unbalanced and tip over.
- Start mounting hardware from the bottom of the rack. If the hardware is mounted at the top of the rack, the rack may become unstable and fall.



WARNING! If a unit falls, it can cause personal injury. When lifting the unit, be sure you have at least 3 or 4 people and a mechanical lift device. Unit positioning, fastening, or other handling should be performed very carefully.

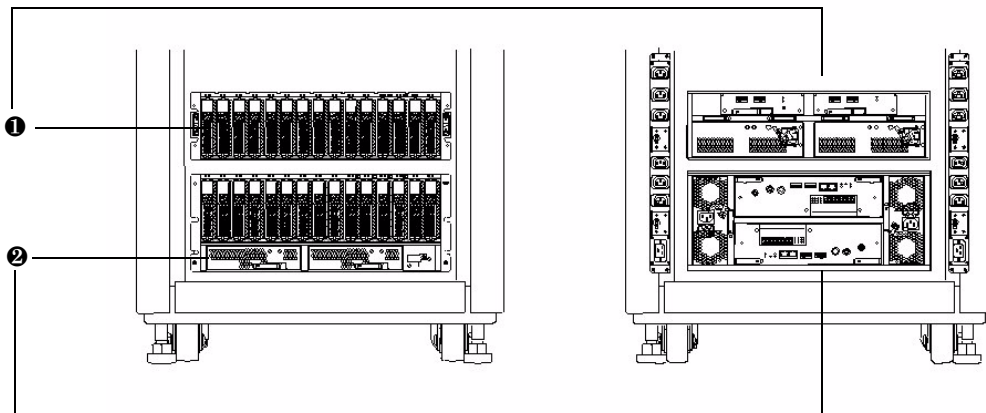

Figure 3-20: Examples of AMS 2000 Family Base/ Expansion Units Mounted at the Bottom of a Rack

Legend:

- ❶ Expansion Unit
- ❷ Base Unit

- The location of the Hitachi AMS 2000 Family base, expansion, and high-density expansion units, along with the layout of your equipment rack and its wiring, are extremely important for proper system operation. Equipment placed too closely together can cause inadequate ventilation and inaccessible panels. These can cause system malfunctions and shutdowns, and can make system maintenance difficult.
- Fully configured AMS base, expansion, and high-density expansion units can weigh hundreds of pounds (see [Floor load ratings on page 4-3](#)). Ensure that all surfaces over which this system will travel can withstand this load.
- Enclosed racks must have adequate ventilation. Be sure not to block the air vents on the front and back of the AMS base, expansion, and high-density expansion units.

- When mounting a chassis in an open rack, ensure that the rack frame does not block the airflow from either the intake or the exhaust ports. If the chassis is installed on slides, check the position of the chassis when it is seated all the way in the rack.
- In an enclosed rack with a ventilation fan in the top, excessive heat generated by equipment near the bottom of the rack can be drawn upward and into the intake ports of the equipment above it in the rack. Ensure that you provide adequate ventilation for equipment at the bottom of the rack.

Height considerations

Rack-mount storage (or server) chassis (devices) are measured in "U's," which is short for "units" and refers to a standard for measuring the height of a device when installed into a rack. A 1U server, for example, is very thin, measuring only 1.75" high, while 2U is 3.5", exactly double the height of 1U. Both the AMS 2000 Family rack and AMS Full-Height Solutions rack are 42U racks.

Be sure the rack has sufficient space to accommodate the Hitachi AMS 2000 Family base, expansion, and high-density expansion units:

- The AMS base unit and AMS high-density expansion unit come in a 4U rack-mount enclosure, which is 4 times the height of 1U.
- The AMS expansion unit comes in a 3U rack-mount enclosure, which is 3 times the height of 1U.

When planning the number of AMS expansion and AMS high-density expansion units to install in a rack, observe the following guidelines:

- With an AMS 2100 base unit installed, a rack can hold up to 8 AMS expansion units and 3 AMS high-density expansion units.
- With an AMS 2300 or 2500 base unit installed, a rack can hold up to 11 AMS expansion units and 5 AMS high-density expansion units.



NOTE: Hitachi AMS 2000 Family and Full-Height Solutions racks have a maximum mountable space of 42U. 2U is reserved at the base of the rack for possible battery units or for ENC cabling when rack-mounting high-density expansion units. If you use the 2U at the bottom of the rack for ENC cabling, additional empty space will be needed at the bottom of the rack to accommodate battery units before you rack-mount hardware. The AMS 2000 Family base, expansion, and high-density expansion units are mounted starting from that point in the racks.

Placing components in the rack

To reduce the risk of injury to persons or damage to equipment, review the following guidelines prior to installing the AMS 2000 Family storage system into the Hitachi Full-Height Solutions rack.

- Install the anti-tip stabilizing plate to provide added stability during installation. See [Stabilizing the rack on page 3-38](#) and [Installing side stabilizer plates on page 3-41](#).

- Obtain assistance to lift and stabilize the product during installation or removal, especially when the product is not yet fastened to the rails.
- Use stable mechanical lift equipment that can handle the weight and that can lift components to the highest levels of the rack (70-80 inches).
- When using a mechanical lift device, do not move it away from the rack frame or lower the platform until the red line on the label affixed to the AMS 2000 Family storage system has crossed the front of the rail kit. Otherwise, the AMS 2000 Family storage system may fall.
- Install equipment with at least one other person.
- Remove all pluggable power supplies and modules to reduce total product weight before lifting it.
- Observe local occupational health and safety requirements and guidelines for manual material handling.
- The handles may be used when raising the AMS 2000 Family storage system, but it is preferable to hold it by the front and rear portions made of sheet metal.
- Be sure that there are no scratches or flaws on the power cables. These defects may cause electric shock or a fire.
- Be sure the storage units are connected to a properly grounded power source to prevent electric shock.
- When mounting the heaviest equipment at the bottom of a Hitachi rack and the lightest equipment at the top, keep the center of mass at or below the 20 U line.
- If mounting more than one AMS 2000 Family storage system, expansion unit, or high-density expansion unit, spread the storage system ratio evenly and to avoid a top-heavy installation. [Figure 3-21 on page 3-32](#) shows an example of such a ratio.

Smallest	1 Full Rack	Spanning Racks
----------	-------------	----------------

Figure 3-21: Sample Configuration Types

Working with racks or components in the rack

Observe the following guidelines when working with racks or components in a rack.

- For all procedures, follow the given methods and sequence of steps.
- Use tools and parts for maintenance specified in the manual; otherwise, personal injury or damage of the rack, as well as deterioration of the product's quality, may result.
- Use only the special tools and instruments specified in this manual or use appropriate commercially available tools and instruments.
- Keep the maintenance area clean.
- Put away parts, materials, or tools when not in use.
- Wear eye protection where liquid may splash or objects may fly about.

- When lifting anything heavy, lift it using your legs with your back kept erect to prevent injury to your back or spine. When lifting, use a proper lifting tool, or ask somebody to assist you.
- Before finishing your work, be sure the rack and any products mounted in it are returned to their original state. Be sure all parts removed during maintenance have been installed back in their original positions in the rack or products mounted in it.
- Be sure that no tool or foreign material is left in the rack.
- Do not repair, remodel, or disassemble the rack and related components. Such actions can injure you and/or damage the equipment.

Air vents and airflow

Observe the following air vent and airflow guidelines.

- Be sure the air vents on the rack are free of obstruction and are inspected periodically. To prevent electric shock or fire, do not place metallic material such as paper clips or any combustible material such as paper into or near the air vents.
- The airflow for the Hitachi AMS 2000 Family base, expansion, and high-density expansion units are from front to back. Hitachi Full-Height Solutions racks have a front door. AMS 2000 Family racks have no door in the front, but have a ventilated door in the back that allows the system to draw air through the front and exhaust air through the back. Do not block the front of mounted components or the rear-ventilated door.
- Do not place metallic material, such as paper clips, or any combustible material, such as paper, into or near the air vents. This may result in electric shock or fire.
- Air flows through the rack from front to back. An optional rear-mounted fan tray is available to further maintain the airflow.
- The airflow of the Hitachi AMS 2100, 2300, and 2500 storage systems that can be mounted in the rack is from front to back. The rack has no door in the front and a ventilated door in the back, which allows the subsystem to draw air through the front and exhaust air through the back. Do not block the front of mounted components or the rear-ventilated door.

Blanking panels

If all the vertical mounting space in a rack is not occupied by rack-mounted products, cover the empty space with blanking panels. Otherwise, the empty gaps between the components can cause airflow changes that may adversely affect cooling within the rack.

Cable guidelines

- Be sure all cables are correctly and fully connected.
- Do not obstruct walkways when routing cables.

- Do not allow heavy material to be placed on cables. Do not place cables near any apparatus that generates heat. Do not step on or subject cables or connectors to shearing or pulling forces. If that happens, the cable jacket could be damaged and could break, resulting in an electric shock, fire, or loss of data.
- Be sure all electrical and signal cables are clean before connecting them. Any dirt on a connector should be removed before inserting the connector into a socket.

Power precautions

Review the appropriate section in this chapter for information about the power precautions for your Hitachi rack:

- For the Hitachi AMS 2000 Family rack, see [page 3-6](#).
- For the Hitachi Full-Height Solutions, see [page 3-12](#).

If installing third-party components in the rack, identify the component's amperage load, and check the current amperage load on the PDUs to determine whether the component can be plugged into a PDU.

To reduce the risk of injury, fire, or damage to persons or equipment:

- Do not overload the AC supply branch circuit that provides power to the rack. Consult the electrical authority having jurisdiction over your facility wiring and installation requirements.
- When planning for power distribution and requirements for your rack configuration:
 - Balance the power load between available AC supply branch circuits.
 - The overall system AC current load must not exceed 80% of the branch circuit AC current rating.
 - If an uninterruptible power supply (UPS) is used, the load should not exceed 80% of the UPS' marked electrical current rating.

To reduce the risk of damage to the equipment:

- Verify that all AC voltage selector switches are set correctly to match your local AC line voltage (230V). If the AC voltage selector switch is not properly set, your components may be damaged when power is applied.
- The installation of rack and mounted components must comply with local and regional electrical regulations governing the installation of Information Technology Equipment by licensed electricians. For electrical power ratings on components, refer to their product rating label or user documentation supplied.

Grounding requirements

All powered equipment should be properly grounded for operation and safety. Ground integrity should be maintained for each connection made in a reliably grounded outlet, such as with the PDUs in the rack.



DANGER! To reduce the risk of electric shock or damage to equipment, follow proper grounding procedures and do not tamper with the pre-installed PDUs. The rack connects to a grounded (earth) power outlet.

Environmental specifications

Table 3-8 lists the environmental specifications for the Hitachi AMS 2000 Family storage systems when mounted in a Hitachi Data Systems rack. These specifications must be observed to ensure the proper operating and storage environment for the storage solution in the rack. The following environmental conditions may damage or decrease the life of the storage system:

- Exposure to direct sunlight
- Rapid change in temperature and/or humidity (such as being near an air-conditioner)
- Proximity (near) to a device which generates electrical noise, such as the ungrounded motor of an air conditioner or washing machine
- Proximity (near) to a device that generates a strong magnetic field (Do not bring any magnet close to the rack or the Hitachi AMS 2000 Family storage system)
- Exposure to dust, dirt, or vibration



NOTE: To reduce the risk of damage to equipment during installation, do not impede airflow to products already mounted in the rack and do not exceed internal rack specifications listed in Table 3-8.

Table 3-8: Environmental Specifications

Item	Specification	
Temperature	In operation (°C)	10 to 40
	In non-operation (°C)	-10 to 50
	In transport/storage (°C)	-30 to 60
	Temperature change rate (°C/h)	10 or less
Humidity	In operation (%)	8 to 80
	In non-operation (%)	8 to 90
	Maximum wet bulb temp. (°C)	29 (non condensing)
Altitude	In operation (m)	-300 to 3,000
	In non-operation (m)	-300 to 12,000

Preparing for installation

This section covers preinstallation guidelines to observe before installing the equipment in a Hitachi AMS 2000 Family rack or Hitachi Full-Height Solutions rack.

Planning considerations

The following information will help you plan an acceptable equipment rack configuration.

- To maintain a low center of gravity and reduce the likelihood of instability, the AMS 2000 Family base, expansion, and high-density expansion units should be installed from the bottom of the rack upwards. This is recommended to ensure personal safety.



NOTE: In the Hitachi AMS 2000 Family rack, 2U is reserved at the base of the rack for possible battery units. This leaves 40U of mountable space in the rack. Hitachi AMS 2000 Family units are mounted starting from that point in the rack.

- To ensure that the internal heat build up is adequately dissipated into the room environment, air flow should not be restricted. It is essential that no vents are blocked, and that the AMS 2000 Family base, expansion, and high-density expansion units are away from a solid surface such as a wall or partition. Air flow through the units is from front to rear.
- Enclosed racks must have adequate ventilation. Ensure that the rack is not overly congested, because each unit generates heat. An enclosed rack should have louvered sides and a fan to provide cooling air.
- In an enclosed rack with a ventilation fan in the top, excessive heat generated by equipment near the bottom of the rack can be drawn upward and into the intake ports of the equipment above it in the rack. Ensure that you provide adequate ventilation for equipment at the bottom of the rack.
- Baffles can help to isolate exhaust air from intake air, which also helps to draw cooling air through the chassis. The best placement of the baffles depends on the airflow patterns in the rack, which can be found by experimenting with different arrangements.

Consideration should be given to the floor ratings of the site where the rack and units will be installed. An unpopulated Hitachi AMS 2000 Family rack weighs 300 lbs (136 kg). For information about the weight of the AMS 2000 Family base, expansion, and high-density expansion units, see [Floor load rating on page 3-7](#).

Receiving considerations for the rack

To receive a fully integrated and configured Hitachi rack, consider the following:

- The dock door at the receiving site must accommodate the height and width of the rack.
- An appropriate freight elevator must be available for deliveries to upper and lower floors.
- Do not lay the rack down because the sheet metal may twist and/or distort.
- If the rack already has components mounted in it, it may be heavy (250 lbs. ~ 1000 lbs. if a Hitachi AMS 2100, 2300, or 2500 storage system is already installed in it).

Tools required

The following tools are required for securing products to the rack-mounting holes on a Hitachi rack:

- Adjustable wrench
- Cage nuts
- Cage nut tool
- Phillips screwdriver
- Screws
- Washers

The racks come with all necessary screws, washers, cage nuts, and cage nut tool. When installing equipment, be sure to:

- Install the front anti-tip stabilizing plate when installing or removing equipment to provide greater stability and safety. See [Stabilizing the rack on page 3-38](#) and [Installing side stabilizer plates on page 3-41](#).
- Mount the heavier equipment at the bottom of the rack first, prior to installing equipment in the upper half of the rack.

Checking the hardware

If the rack is ordered empty, it should come with all components. If additional features or options were ordered, or if the rack was ordered with Hitachi Data Systems products pre-installed, verify that all items have been received.

Casters

The casters facilitate movement of the rack across short distances in order to position it for final installation. As soon as the rack is in its final position for installation, make sure that the full weight of the rack is supported by the leveling feet.

The casters can only support the weight of the rack with installed components for short periods of time and not designed to support the full weight of the rack on a long-term basis. If this occurs, the casters may be damaged.

Leveling feet

The leveling feet, located beside each caster on the Hitachi rack, unscrew and extend to the floor. These feet support the rack and help compensate for uneven surfaces as shown in [Figure 3-22](#).

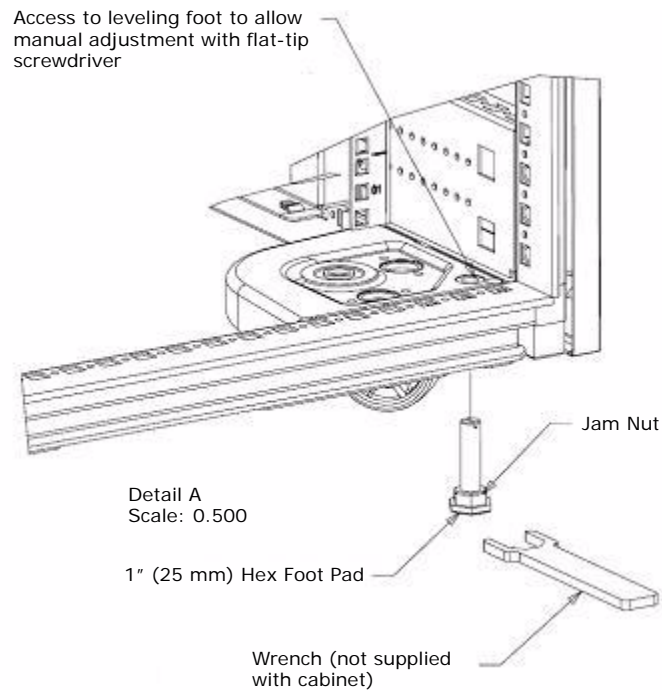

Figure 3-22: Example of Leveling Feet

If access is available to the top of the leveling foot from the inside of the cabinet, a flat tip screwdriver may be used to drop the leveler down. Alternatively, you can loosen the leveler by turning it clockwise with a wrench to fit into the 1 inch hex pad. Once leveled, the jaw nuts can be used to secure the leveler in place.

The leveling feet are screwed in at the factory and tightened to avoid loosening during shipment. If you have difficulty loosening up the levelers from top, use the wrench to break them loose from the bottom.

Stabilizing the rack

Hitachi racks allow many components to be installed vertically. Plan the weight and location of the components to place the center of mass as much as possible below the mid-point of the rack. To reduce the risk of danger to persons or equipment, follow the safety guidelines and stabilize the rack as described in the following paragraphs.

If you are installing a single (stand-alone) rack, be sure the rack is level and that it has been stabilized before installing the components. If an unstable rack is loaded with components, it may become unbalanced and fall over.

If installing expansion units in adjacent racks, bay the racks together and be sure both racks are level and stabilized before installing components in the rack.

To stabilize the rack, observe the following guidelines:

- Stabilize the rack frame at its final installation location by adjusting the leveling feet.
- Using an adjustable wrench, turn each leveling foot clockwise until the clearance between the caster and the floor is 2.5 mm. The full weight of the rack should be resting on the leveling feet, and not on the casters.
- Adjust the leveling feet so that the tilt of the rack (forwards, backwards, left or right) becomes 0.0 ± 2 mm.
- When extending equipment out of the rack, be sure the front stabilizer plate is installed and extend only one item at a time. Extending two or more items of equipment at a time may cause the rack to become unstable and tip over.
- Front and side stabilizer plates must be installed on racks with AMS expansion units.
- Always follow safety precautions and common sense.

Figure 3-23 shows an example of how to stabilize a rack by lowering the leveling feet.

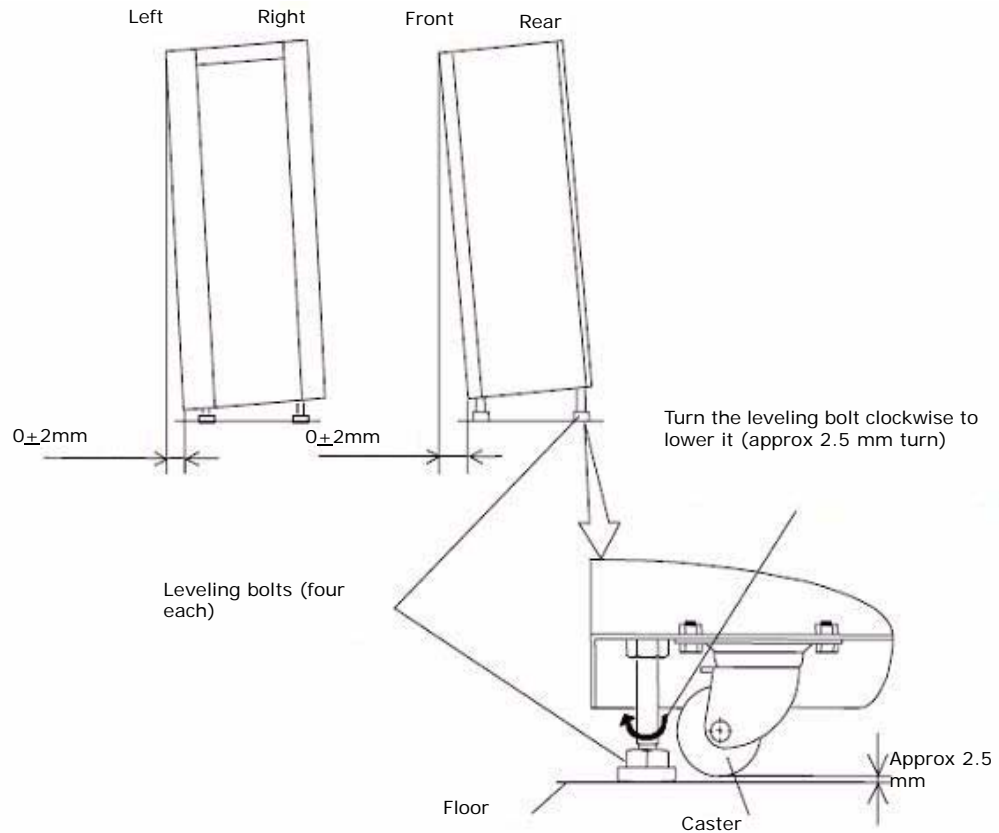

Figure 3-23: Example of Lowering the Leveling Feet

Installing side stabilizer plates

Figure 3-24 shows an example of how to install the side stabilizer plates.

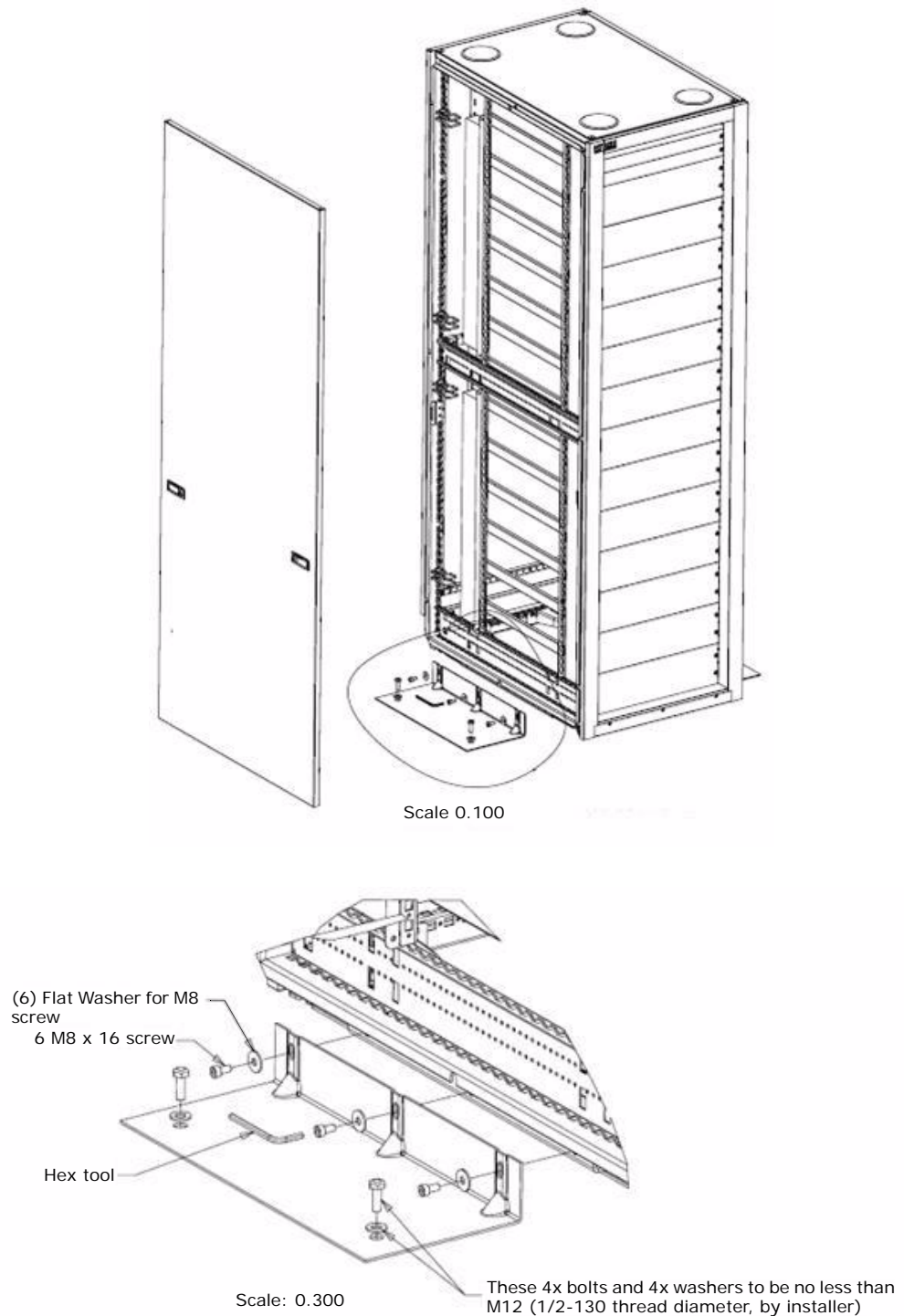

Figure 3-24: Example of Installing the Side Stabilizer Plates (Detail A)

The following procedure describes how to install the side stabilizer plates. Installing side stabilizer plates is required only when the rack is installed as a stand-alone rack system with no equipment mounted in it. The side plates keep the rack from tipping on its sides. If equipment is mounted in the rack, the use of these side stabilizer plates is optional.

1. Remove side stabilizer plates from cabinet. The sidewalls are grounded inside the cabinet. To remove them, unlock the latches and then pull panel out and up.
2. Place the stabilizer plate as shown in [Figure 3-24 on page 3-41](#) so it can mate against the bracket at the bottom sides of frame and align with the holes.
3. Using the hardware supplied, attach both plates as shown in Figure 3.4 using the included hex tool.
4. Reinstall the side stabilizer plates.
5. Using the holes on the flat plate's surface, install bolts and washers to anchor the cabinet to the floor. This hardware is not included in the kit.

[Figure 3-25](#) shows the final view after everything is installed

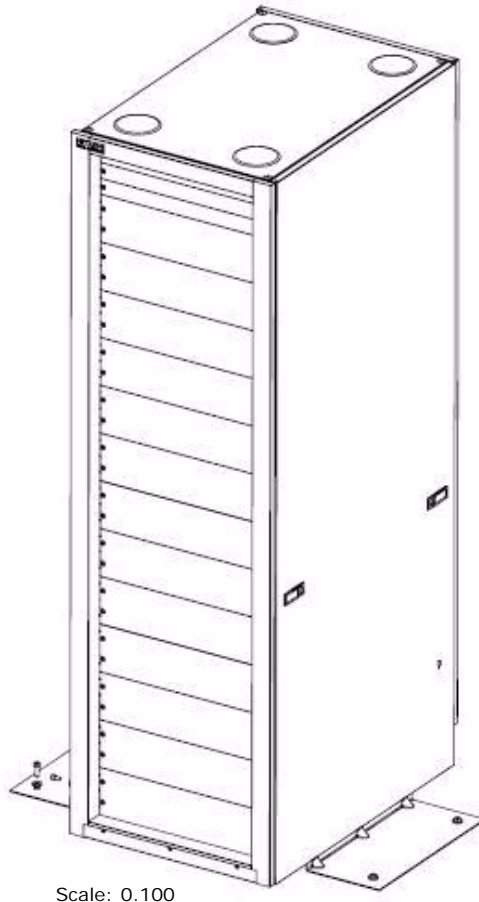

Figure 3-25: View of Hitachi Rack with Side Stabilizer Plates Installed

Moving the rack

The maximum allowable inclination angle for the Hitachi rack is eight degrees (8°). When moving the rack across steep slopes or different floor levels, use a gangway as shown in Figure 3.5 to form a slope with an inclination angle (slope) of less than eight degrees.

To reduce the risk of injury to persons or damage to equipment, it is recommended that all equipment be removed from the rack, in order from top to bottom. Transport the rack and the components individually to the desired location.

To move the rack with the mounted components in it, it is recommended to transport on the same pallet on which the rack was shipped. Take necessary precautions when loading onto the pallet. Package and secure the rack on the pallet as it was shipped and received.

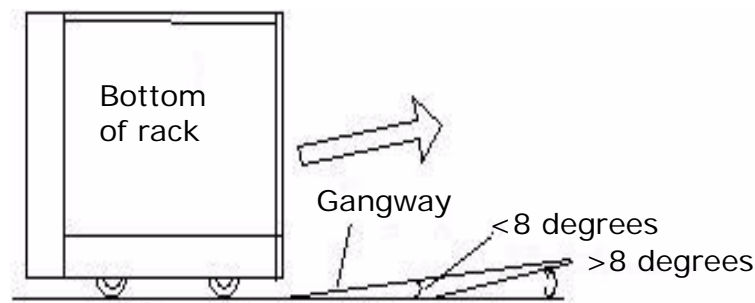

Figure 3-26: Maximum Incline (Slope) for Moving the Rack

Securing multiple racks together with the baying kit

The baying kit is used to secure multiple racks together. To secure multiple racks, use the following procedure.

1. Remove side panels from the cabinets that are to be bayed together.
2. Open the contents of the baying kit.
3. Place the cabinets side by side until they touch.
4. After the cabinets are leveled, remove the two front-center roof installation screws using the TORX® tip tool supplied.
5. Place the baying plate on top (aligning the holes), and then reinstall the roof installation screws into both holes to connect the cabinets (see Detail A in [Figure 3-27 on page 3-44](#)).
6. For the baying connection at the front bottom, the M12 bolts must be started by hand into the holes at the bottom of the frame until they are high enough to clear the TORX tool for final tightening (see Detail B in [Figure 3-28 on page 3-45](#)).

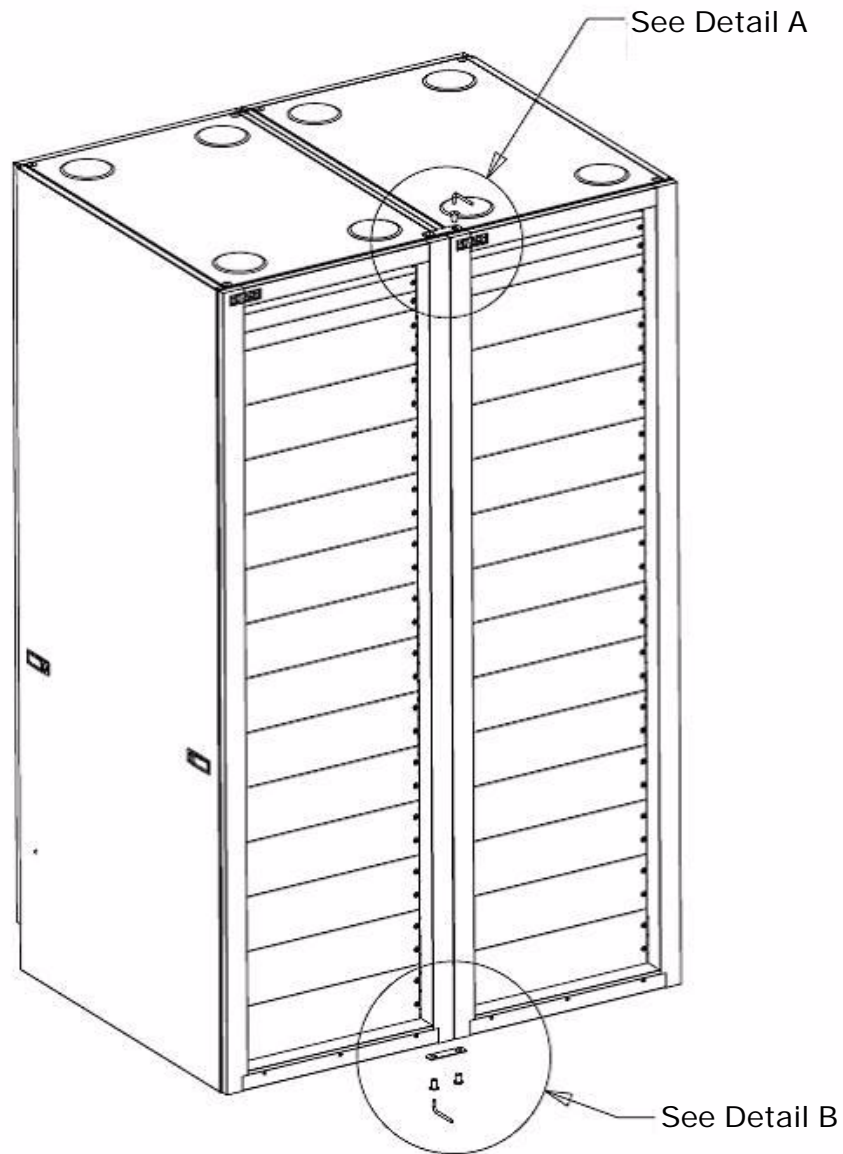
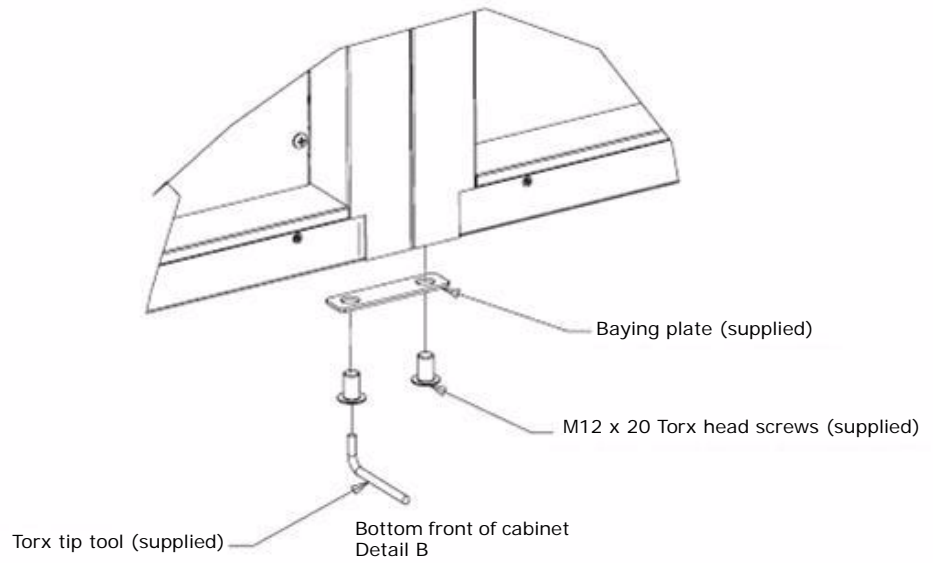
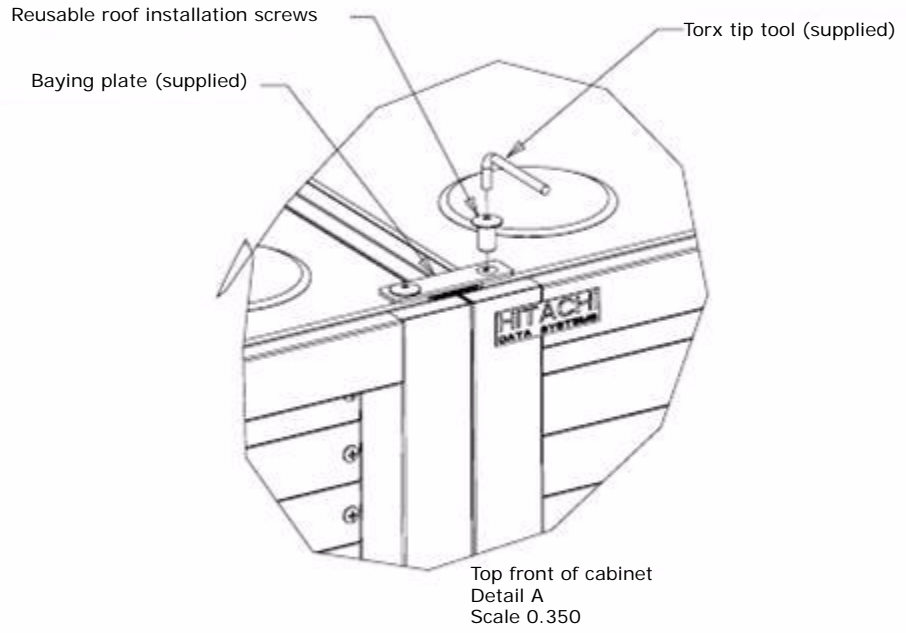

Figure 3-27: Baying Kit



**Figure 3-28: Baying Kit (Details A and B)
(continued from previous page)**

Rear baying instructions

1. Remove rear doors to access cabinet frames.
2. Look for a common notch in frames where the baying connection will be made (one at bottom and one at the top). See [Figure 3-29](#).
3. When the cabinets are even, place the hex connecting bushing. Use a 4mm hex Allen tool to put an M6 cap screw through the frame open square. This will align the internal slot to reach the hex bushing. (A magnetic tool is recommended because screws may fall off inside the frame cavity.)
4. Repeat step 3 with the rest of the screws and the bushing installation.

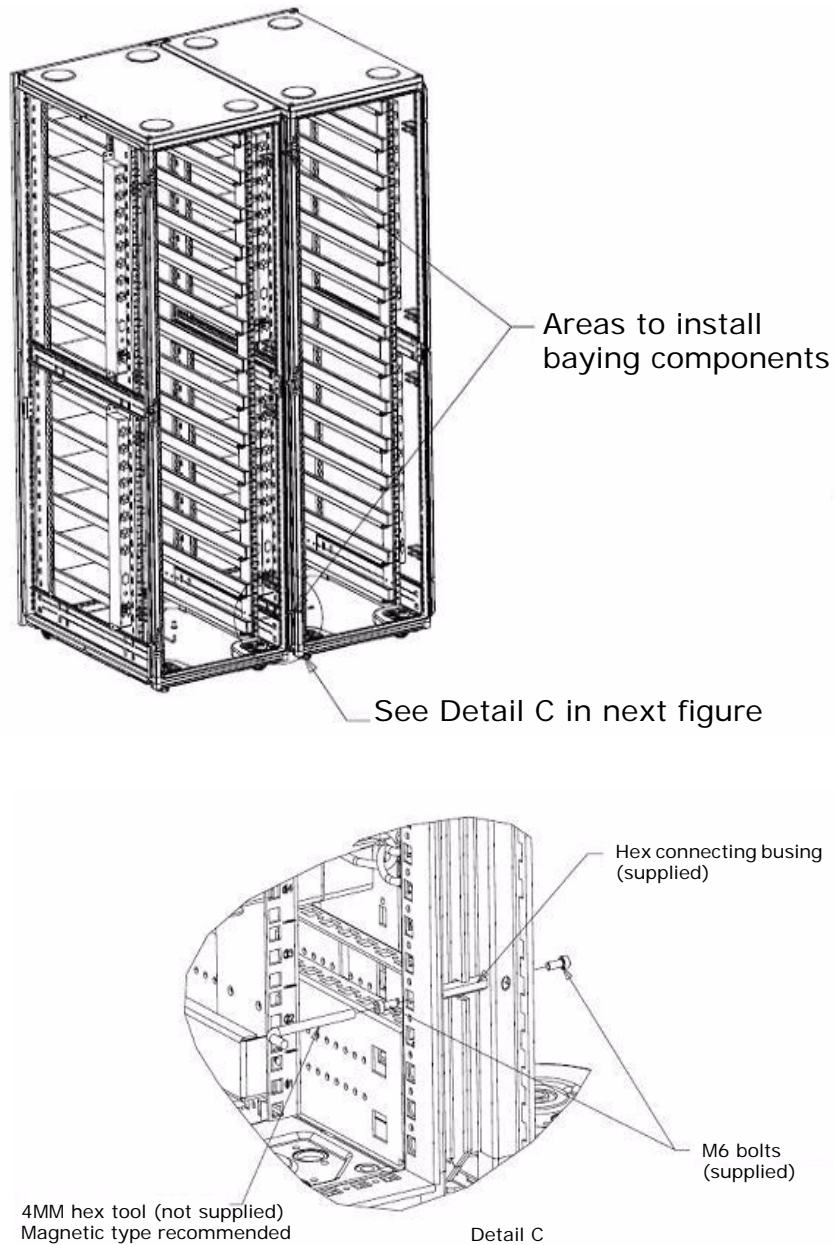

Figure 3-29: Baying Kit

Opening and closing the side panels

The side panels can be locked and unlocked with keys supplied with the rack. Once unlocked, press the release levers inward and pull the panel outwards and lift to remove. Reverse these procedures when reinstalling the side panels.

Installing rack equipment

This section describes how to install equipment in a Hitachi AMS 2000 Family rack and Hitachi Full-Height Solutions rack. The topics covered in this section are:

- [Installation steps on page 3-47](#)
- [Installing cage nuts on page 3-48](#)
- [Installing and uninstalling the anti-tip stabilizing plates on page 3-48](#)
- [Installing blanking panels on page 3-50](#)

Before installing equipment, read the safety information in [Safety information on page 3-26](#).

When installing equipment, be sure to:

- Install the front anti-tip stabilizing plate when installing or removing equipment to provide greater stability and safety. See [Stabilizing the rack on page 3-38](#) and [Installing side stabilizer plates on page 3-41](#).
- Mount the heavier equipment at the bottom of the rack prior to installing equipment in the upper half of the rack.
- Refer to the specific instructions included with the equipment you will mount.

For instructions about mounting a specific Hitachi AMS 2000 Family Storage system into the rack, refer to the appropriate Hitachi Data Systems installation and user guides.

Installation steps

Most installations of equipment in the rack involve the following steps:

1. Determine location in the rack where the components will be mounted.
2. Remove side panels or rear door of rack (not necessary but may make installation easier).
3. Install railkits or mounting hardware that equipment will rest on in the rack as follows:
 - a. Prepare the mounting hardware.
 - b. Insert the applicable cage nuts in the rack to which the railkits will be secured.
 - c. Install the railkits/mounting hardware into the rack.

- d. Install the front anti-tip stabilizing plate to provide greater stability and safety. See [Stabilizing the rack on page 3-38](#) and [Installing side stabilizer plates on page 3-41](#).
4. Install the equipment into the rack as follows:
 - a. Determine what mounting holes will be used for securing the equipment to the rack, and install cage nuts at these locations.
 - b. Insert equipment into the rack using the previously installed railkits/mounting hardware.
 - c. Secure the equipment to the rack with screws that secure to the cage nuts as determined in Step 3.
5. When the rack is in its final destination, keep the bar bolted to the rack for maintenance and safety purposes.
6. Identify the correct power source (220V) which the equipment will be connected to, and then connect to power.
7. Install the blanking panels.
8. Reattach the side panels and/or rear door (if they have been removed).

Installing cage nuts

When installing railkits or securing equipment to the rack, cage nuts are inserted into the square holes. Screws can then attach to the cage nut for securing the railkits or equipment.

To install cage nuts, insert one curved edge into the square hole, and use the cage nut tool to pull the other end through the square hole as shown in [Figure 3-30](#).

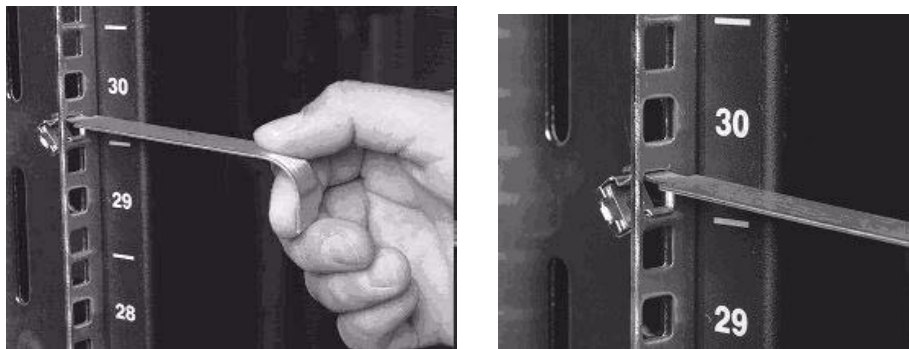

Figure 3-30: Installing the Cage Nuts

Installing and uninstalling the anti-tip stabilizing plates

Install anti-tip stabilizing plates with Hitachi AMS 2000 Family racks and Hitachi Full-Height Solutions racks to provide further stability to the rack. Front and side anti-tip plates are mandatory when installing AMS 2000 Family high-density expansion units. This extra stability is especially important when installing equipment into the rack or when removing equipment from it.

Figure 3-31 shows the installation of the anti-tip stabilizing plate. Reverse these actions for uninstalling the anti-tip stabilizing plate

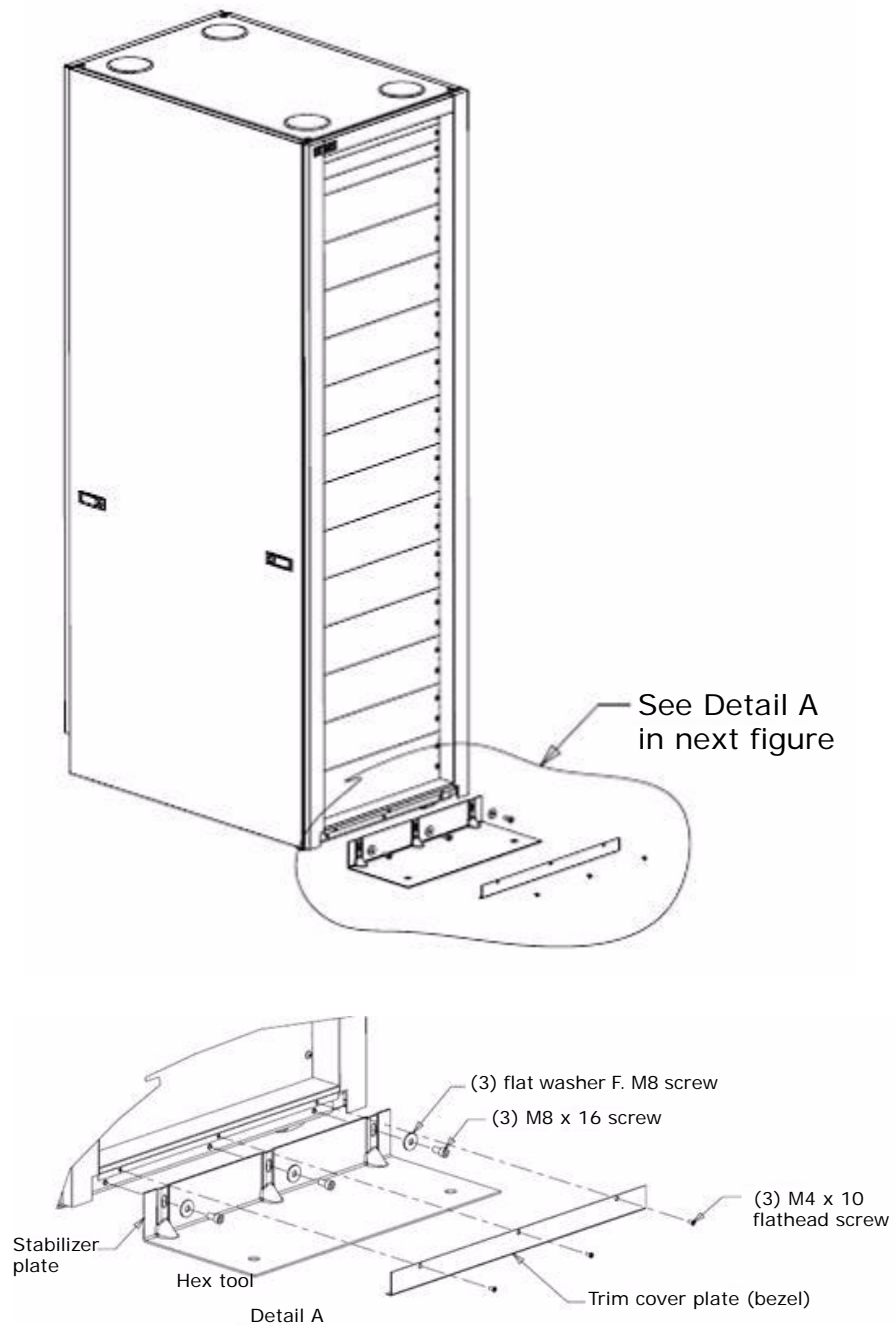

Figure 3-31: Installing and Uninstalling the Anti-Tip Stabilizing Plate

To install the stabilizer plate:

1. Remove the trim cover plate from bottom of bezel and set it aside for reinstallation later.
2. Unpack the stabilizer plate kit.

3. Place the stabilizer plate as shown to mate with bracket at bottom of frame.



NOTE: The plate may have to be tucked in at a slight angle to clear the bezel bottom flange. Rest the large flat surface fully on the floor surface.

4. Using the washers, M8 screws, and tool in the kit, secure the plate to the frame.
5. Reinstall the trim cover plate with the M4 flat head screws you removed in step 1.

Installing blanking panels

Blanking panels should be installed to cover any empty space at the front of the rack. This will ensure adequate airflow to the equipment in the rack if the rack is not completely filled.

When installing blanking panels, follow these steps:

1. Place the blanking panel on the rack as a template to determine which holes will require cage nuts.
2. Insert the cage nuts.
3. Secure the panels to the rack by screwing them onto the rack at the cage nut locations.

Rack-mounting AMS high-density expansion units

For a complete description of guidelines, best practices, and procedures for rack-mounting AMS 2000 Family high-density expansion units, see [Chapter 5, Preparing for AMS high-density expansion units](#).

Post-installation considerations

The following sections provide guidelines to consider after you install equipment in the Hitachi AMS 2000 Family racks and Hitachi Full-Height Solutions racks.

Casters

The casters facilitate movement of the rack across short distances in order to position it for final installation. As soon as the rack is in its final position for installation, make sure that the full weight of the rack is supported by the leveling feet.

The casters can only support the weight of the rack with installed components for short periods of time and not designed to support the full weight of the rack on a long-term basis. If this occurs, the casters may be damaged.

Precautions for inspection and cleaning

Observe the following precautions when inspecting and cleaning the rack.

- If the equipment must be powered off, perform the power-off sequence described in the storage solution user's guide before proceeding with maintenance.
- Do not work on the equipment or rack in a damp or flooded environment.
- Do not obstruct access to the rack with parts or tools.
- If the rack has a door, before performing the work with the door open, take off metal watches or jewelry to prevent electric shock. If you wear metal-frame glasses, do not touch the equipment.
- Ensure that loose clothing, jewelry, or hair does not become tangled in moving components.
- There are high-voltage parts in the equipment. Observe the cautionary statements in this chapter to make sure that high-voltage components are not touched during maintenance. Another person should be on alert in case the power feed to the equipment needs to be quickly turned off.
- After the power feed to the equipment is shut off, electricity remains in the equipment for a period of time. Do not touch any components other than those indicated in this chapter.
- The equipment can become extremely hot. Do not touch any parts other than those indicated in this chapter.
- When working with the door open, wear cotton gloves to prevent your hands from touching sharp objects.

EMEA rack

This section describes the rack used in Europe, the Middle East, and Africa (EMEA). The following figures show different views of the EMEA rack.



Figure 3-32: Front and Rear Views (EMEA Rack)

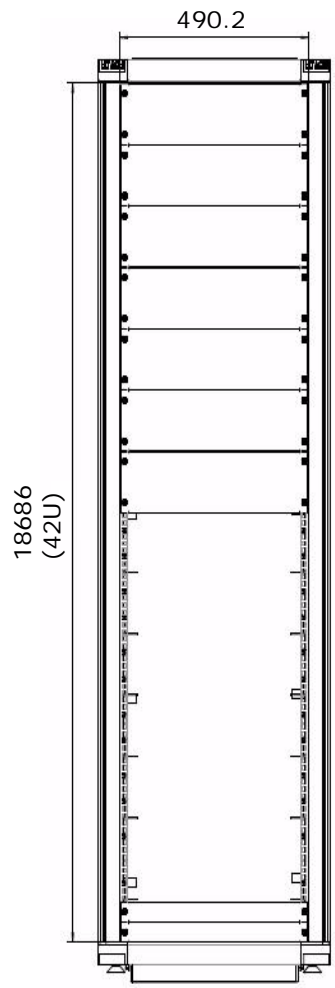

Figure 3-33: Front View (EMEA Rack)

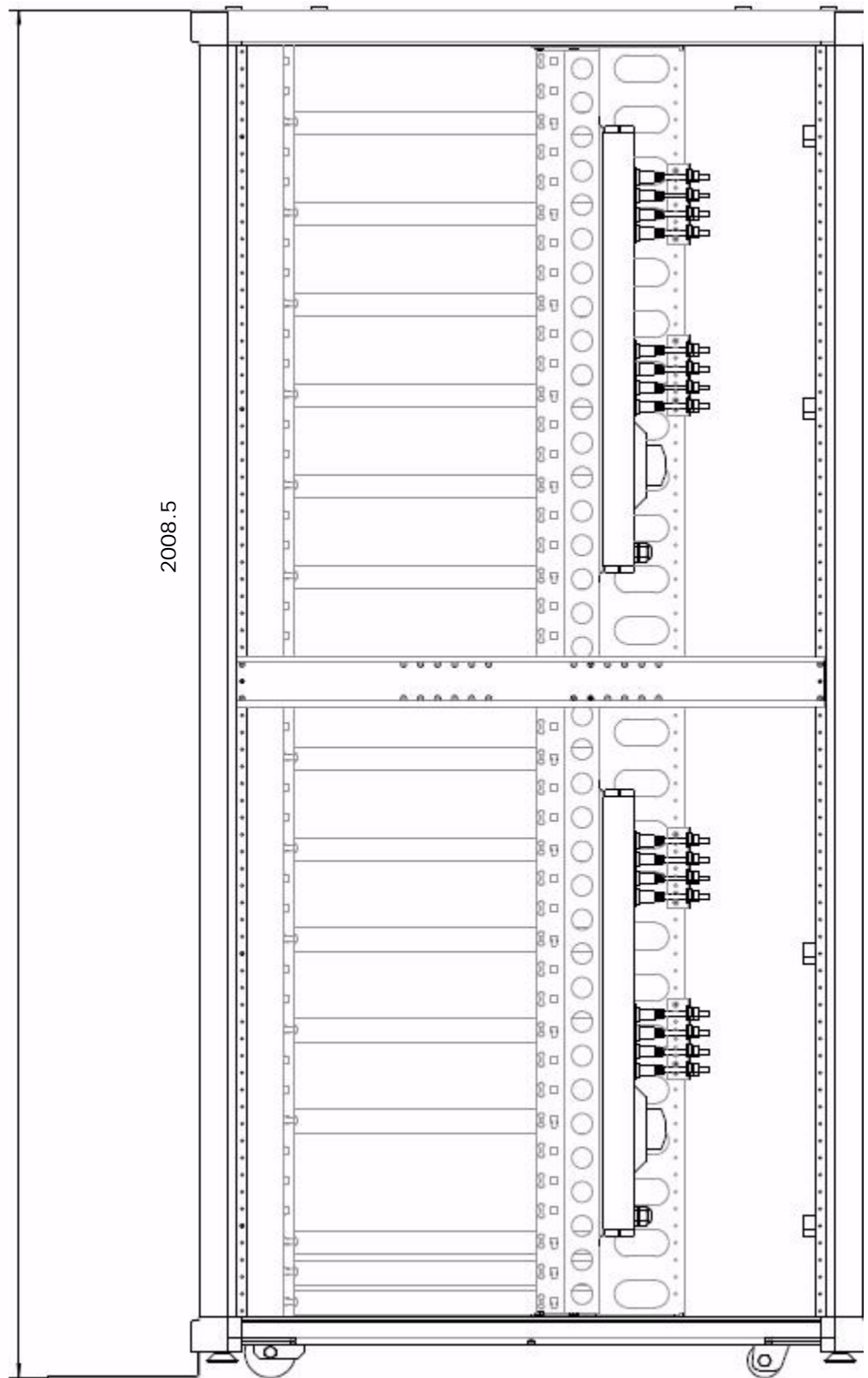

Figure 3-34: Detailed View (EMEA Rack)

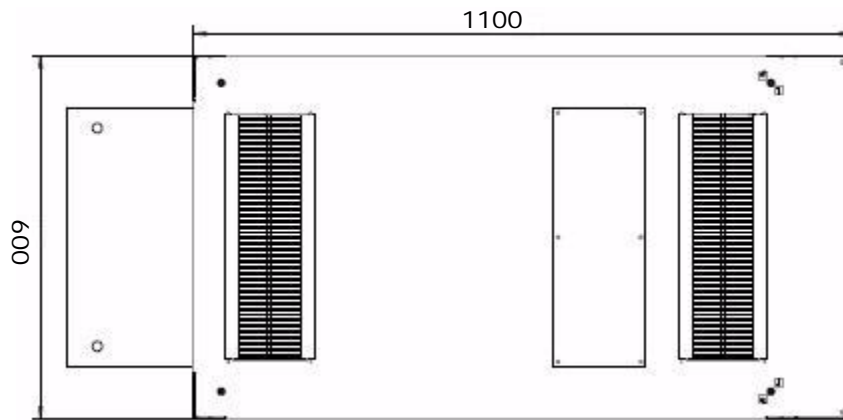

Figure 3-35: Top View (EMEA Rack)

Specifications

Table 3-9: EMEA Rack Specifications

Item	Specification	Item	Specification
P-code	A3BF-AMS	Rack	Welded aluminium
Dimensions (HxWxD)	2010 x 600 x 1100 mm	Roof	Solid with opening for cable assembly Ability to optionally mount fan
Usable Volume (HxWxD)	1868x490/451x1050 mm	Side Panels	Solid with locks
Weight (approx)	135 kg	Mounting	Four 19-inch vertical rails, with "U" markings
Static Weight Capacity*	900 kg	Casters	Two fixed in the front Two swivel casters in the rear
Power	200-240 VAC Four 30 Amp power strips	Dynamic Load	500 kg
Source Circuit Breaker	Dedicated 32A per PDU	Leveling Feet	Four
PDU Source Power Cord	Power cord: Rated 32A, 200-240V IEC 309 Plug	Cable Management	Cable ring guides in the rear
PDU Amperage	32A total 16A Usable/Derated, per 4 outlets 10A max. capability per outlet	Grounding	Black ground straps (door/sides/roof)
Indicator	On / Off label on switch	Blanking Panels	7x 3U and 2x 1U blanking
Component Power Cords	Power cord 0.6 Meters, 250V, 10 Amps, c14/c13 connector	Support Rails	Rack ships with 15 preinstalled rails
Retainer Clip	Eight, one per outlet (prevents power cords from being disconnected accidentally)	Front Stabilizer Plate	One "L"- shaped stabilizer plate included with the rack for front use
Temperature	Operating: 0° to 50° gr.C Storage: -25° to 65° gr.C	Stabilizer Plate	Required for stand-alone configurations with high density expansion unit, (p/n 7846414)
Humidity	0 to 95%, non-condensing	Safety Approvals (rack with power strips)	<ul style="list-style-type: none"> • EN 60950 • IEC 297 • IP 20 Protection (exclusive of cable entry) • CE
Color	Black (RAL 9011)	Options	Fan tray (installable in roof) Shelf max 100 KG load Shelf max 40 KG load
Mounting Height in EIA Units	42	Baying Interconnect Kit	A17C-EXTERN-9011 (set of 4)

* Static Weight Capacity refers to the amount of weight the rack can hold with leveling feet.

Installation and maintenance clearance areas

See [Figure 3-36 on page 3-55](#).

$$C = (A-W)/2 \text{ mm}$$

$$D = 1100 \text{ mm}$$

$$E = 600 \text{ mm}$$

$$W = 600 \text{ mm}$$

Preparing the site

Before you install the Hitachi AMS 2000 Family storage system, it is important to plan the site where the units will reside. This usually involves more than just “shuffling equipment.” The units must fit through doors and have a spot in the data center that provides adequate power and network connectivity. If units are added to an existing storage setup, the additional units may require more cooling in the data center.

Therefore, it is vital to prepare a location for the units and implement any facilities changes needed to accommodate the units in advance. Changes may involve reinforcing the elevated floor where the units will be located, updating electrical service (for example, more plugs or higher amperage), or adding ventilation for supplemental cooling (if necessary).

This chapter provides site-preparation guidelines to ensure that you are fully prepared for a successful installation. The topics in this chapter include:

- [Facilities considerations](#)
- [User-supplied items](#)
- [Rack-mount considerations](#)
- [Rack-mount considerations](#)
- [AMS high-density expansion unit considerations](#)
- [Server considerations](#)
- [Storage features](#)

Facilities considerations

Selecting a site

The following precautions will help you plan an acceptable operating environment for the Hitachi AMS 2000 Family base, expansion, and high-density expansion units and will help you avoid environmentally caused equipment failures.

- Select a flat location that is clean, with no dust or exposure to direct sunlight or vibrations. Avoid inclined floors.
- The location should not be prone to variations in temperature and humidity.
- Do not store or install the equipment in a high temperature environment of 40 degrees centigrade or more, because battery life will be shortened.
- The location should not be near strong magnetic fields or close to a device that generates electric noise.
- Electrical equipment generates heat. Ambient air temperature might not be adequate to cool equipment to acceptable operating temperatures without adequate circulation. Ensure that the room in which the units operate has adequate air circulation.
- Always follow the ESD-prevention procedures described in [Electrostatic safety on page 2-7](#) to avoid damage to equipment. Damage from static discharge can cause immediate or intermittent equipment failure.
- Ensure that the enclosure cover is secure. The enclosure is designed to allow cooling air to flow effectively within it. An open chassis allows air leaks, which may interrupt and redirect the flow of cooling air from internal components.



NOTE: For environmental specifications, see [Appendix A, General specifications](#).

Floor load ratings

The floor space at the installation site must be strong enough to support the combined weight of the:

- AMS 2000 Family base unit.
- All AMS expansion and high-density expansion units.
- The rack in which the AMS 2000 Family base, expansion, and high-density expansion units are installed.
- All associated equipment.

Observe the following AMS weight considerations.

- A fully populated AMS 2100 or AMS 2300 base unit weighs approximately 112 pounds (51 kg).
- A fully populated AMS 2500 base unit weighs approximately 101.2 pounds (46 kg).
- An AMS expansion unit weighs 88 lbs (40 kg).
- An AMS high-density expansion unit weighs 206.8 pounds (94 kg).

To ensure adequate load-bearing capacity, plan for the maximum configuration.

For rack-mounted installations, the weights above do not include the rack itself, so please add the weight of the rack to the values shown above. The maximum allowable weight in a Hitachi rack is 2,000 pounds (907 kg). For more information about Hitachi racks, see [Chapter 3, Rack mounting a storage system](#). If you use a different rack, refer to the documentation for that rack.

Space requirements

The installation site also requires sufficient space for installation, operation, and servicing the units and sufficient ventilation to provide a free flow of air to the units. To prevent overheating, the AMS 2000 Family base, expansion, and high-density expansion units have ventilation holes on the front and back of the enclosure. Leave at least 2 inches (5 cm) of open space at the front and rear of the units. There should also be enough space to view LEDs and access drives and interface connectors. For more information, see [Table 3-3 on page 3-9](#).

Power considerations

Hitachi AMS 2000 Family storage systems have an input power rating of 125V–200V operation. The units come with a set of electrical power cables. A label near the power cord indicates the correct voltage, frequency, current draw, and power dissipation that should be used with the cable. Please be sure to use the appropriate power cable for your location. Also, check the power at your site to ensure that you are receiving “clean” power (free of spikes and noise). Install a power conditioner if necessary.



NOTE: For rack power considerations, see [Chapter 3, Rack mounting a storage system](#).

Electrical requirements

The AMS 2000 Family base unit, expansion unit, and high-density expansion unit are equipped with two fully redundant wide-ranging power supplies that automatically accommodate voltages to the AC power source. The power supplies operate within the range of 100-125 VAC or 200-240 VAC. The power supplies meet standard voltage requirements for both domestic (inside USA) and international (outside USA) operation. When connecting to an AC source, be sure the current does not exceed the rating of the power source circuitry. This includes cabling, power distribution units, filters, and any other components through which the main AC flows.

These requirements must be added to the power demands of any other electrical devices installed in the equipment rack to arrive at a total power consumption figure. In addition, surge currents must be accommodated. Disk drives normally consume twice the amount of current at startup as they do during steady-state operation.

If you purchase the AMS 2000 Family base unit, expansion units, and high-density expansion units pre-installed in the Hitachi AMS 2000 Family rack, the rack will require four 30 amp, 208 Volt circuits, source power, which use the L630P plug and require L630 connectors.

For additional information, please refer to the specifications in the hardware guides and reference guide for the AMS 2100, AMS 2300, and AMS 2500 storage systems.

Environmental requirements

For information about the environmental conditions that are prerequisite to installing the Hitachi AMS 2000 Family storage system, see [Environmental specifications on page A-3](#).

Service clearance

The installation area and service clearance in [Figure 4-1 on page 4-5](#) are required to install Hitachi AMS 2000 Family storage system. Be sure to install the units in a location that conforms to the requirements in the figure to ensure that the units can be accessed and receives the proper ventilation. All dimensions in the following figure are stated in mm.

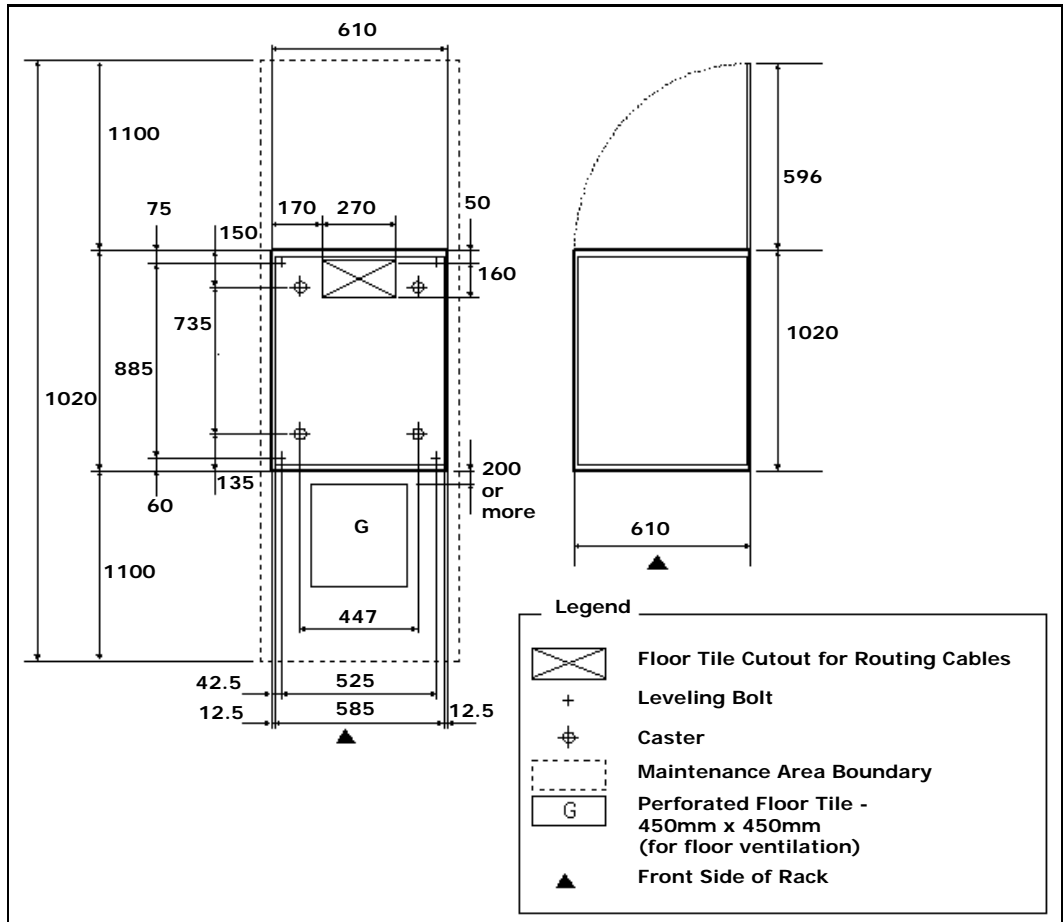

Figure 4-1: Service Clearance Areas

Supported configurations

Hitachi 2000 Family storage systems can be used in a direct-connect point-to-point or switch configuration.

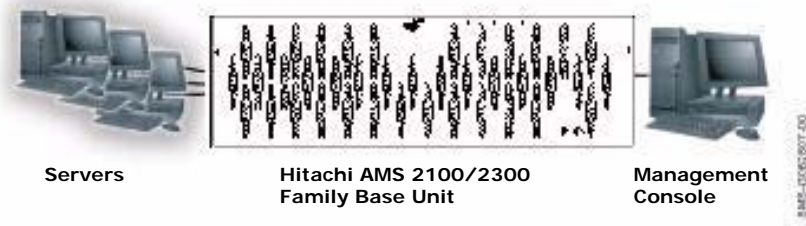

Figure 4-2: Example of a Direct-Connect Configuration

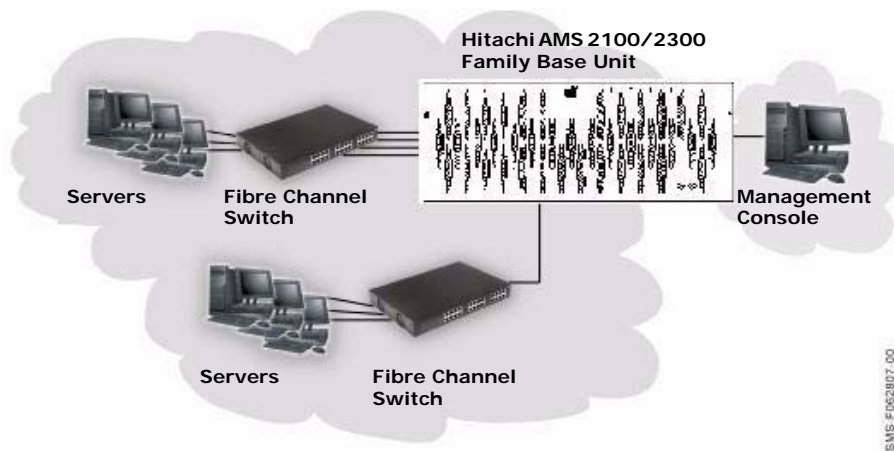

Figure 4-3: Example of a Switch Configuration

User-supplied items

To install Hitachi AMS 2000 Family storage systems, please have the following user-supplied items available. For information about compatible products, please refer to the interoperability information at www.hds.com/products/interoperability.

All installations

- A personal computer (PC) that will act as a management console (see [Requirements for array management on page 4-7](#))
- The Hitachi AMS 2000 Family rack or an equivalent rack
- Two AC outlets (100 V to 120/200 V to 240 V)
- Internet access via Internet Explorer v7.0, Internet Explorer v6.0 (Service Pack 1) or Mozilla v1.7, with pop-up blockers disabled and Java Runtime Environment (JRE) v6.0



NOTE: JRE v6.0 can be downloaded from <http://java.com/en/download/> and installed by following the on-screen prompts.

- A host server equipped as described under [Host server requirements on page 4-8](#).

Fibre channel installations

- A Fibre Channel multi-mode cable for each Fibre Channel port that will connect to the user's storage network.
- A host server that contains at least one Fibre Channel host bus adapter (HBA) compatible with the Hitachi AMS 2000 Family storage systems.
- *Optional:* One or more Fibre Channel switches for switch configurations (see [Supported configurations on page 4-6](#)).

iSCSI installations

- An IP address, subnet mask, gateway (if applicable), and Ethernet cable for each iSCSI data port that will connect to your storage network.
- iSCSI HBAs host bus adapters or network interface cards (NICs) compatible with the Hitachi 2000 Family storage systems.
- An iSCSI initiator compatible with the Hitachi 2000 Family storage systems.
- *Optional:* One or more Gigabit Ethernet LAN switches for switch configurations (see [Supported configurations on page 4-6](#)).

Requirements for array management

- An IP address for each management port on the base unit
- A PC that meets the following minimum requirements (for an optimum experience, use a new or dedicated PC or server):
 - Processor: Pentium 4 1 GHz (2.4 GHz or faster recommended)
 - Random Access Memory: 1 GB
 - Disk space: 1.5 GB
 - Video resolution: 800 x 600 dots per inch (1024 x 768 or higher recommended)
 - A network-interface card (NIC)
- An Ethernet cable for direct or switch access to management ports:
 - For direct connection to the management port, use a cross-over cable.
 - If connecting to the management port using a switch or hub, use a straight-through cable.



NOTE: When you assign an IP address to a base unit to manage it out-of-band, for security reasons, make sure the IP address is on a private network rather than a publicly routable network.

Host server requirements

A host server equipped as follows:

- A supported Fibre Channel HBA for Fibre Channel installations, or an iSCSI HBA or NIC and iSCSI initiator for iSCSI installations
- One of the following operating systems:
 - Microsoft Windows XP (Service Pack 2)
 - Microsoft Windows Server 2003 (Service Pack 1/2)
 - Microsoft Windows 2000 (Service Pack 3/4)
 - Microsoft Windows Server 2003 (Service Pack 1/2)
 - Microsoft Windows Server 2003 R2
 - Microsoft Windows Server 2003 R2 (x64)
 - Microsoft Windows Server 2003 X64
 - Microsoft Windows Vista
 - Microsoft Windows 7, x64 and x86 (no Service Pack)
 - Microsoft Windows Server 2008 R2 (no Service Pack)
 - Sun™ Solaris™ v8, 9, or 10
 - Red Hat Enterprise Linux AS 4.0 (update 1)



NOTE: Microsoft Windows XP and Windows Server 2003 R2 can also operate as a guest operating system of VMware ESX Server 3.1.x when Windows update KB922760 or newer is installed.

Rack-mount considerations

For general rack-mount considerations, see [Chapter 3, Rack mounting a storage system](#). For rack-mount considerations specifically for AMS high-density expansion units, see [Chapter 5, Preparing for AMS high-density expansion units](#).

AMS high-density expansion unit considerations

For information specific to AMS high-density expansion units, see [Chapter 5, Preparing for AMS high-density expansion units](#).

Server considerations

Hitachi AMS 2000 Family storage systems are compatible with a variety of servers and operating systems. For the latest information, please refer to the interoperability information at www.hds.com/products/interoperability. Please have all the necessary server items available (such as cables and Fibre Channel host bus adapters) prepared before you perform the installation.

Storage features

Hitachi AMS 2000 Family storage systems may come with pre-installed storage features for simplifying tasks such as backup and recovery, LUN management, and monitoring system performance. For the latest information about storage features available for the Hitachi AMS 2000 Family storage systems, please refer to the interoperability information at www.hds.com/products/interoperability.

Preparing for AMS high-density expansion units

This chapter provides site-preparation guidelines for AMS high-density expansion units.

The topics in this chapter include:

- [Overview](#)
- [Configuration rules](#)
- [Floor load ratings](#)
- [Installing AMS high-density expansion units in a rack](#)
- [Bill of materials](#)
- [Ordering checklist](#)
- [Shipping](#)
- [Installation and support](#)
- [High-density expansion unit specifications](#)

Overview

AMS high-density expansion units address the enterprise's need to limit facilities cost and maximize space utilization by minimizing storage footprint through increased storage density for the enterprise. An AMS high-density expansion unit can connect to an AMS 2100, 2300, or 2500 base unit or to other high-density expansion units.

An AMS high-density expansion unit consists of two independent storage sections. Together, the two sections contain:

- Four redundant power supplies (two per section). If one power supply in a section fails, the other one can supply sufficient power and cooling to the section until the failed power supply is replaced.
- Four redundant ENC control units (two per section) that manage the drives. Each ENC control unit has ENC-IN and ENC-OUT ports for connecting an AMS 2100, 2300, or 2500 base unit and other high-density expansion units.
- Up to 48 SATA drives (from 0 to 23 per section) or up to 38 SAS drives (slots HDD_L19 through HDD_L23 on side A slots HDD_R19 through HDD_R23 on side B are vacant). See [About AMS high-density expansion units on page 1-11](#).

An AMS high-density expansion unit weighs 178 lbs (80.91 kgs) without rails and cables, and requires a special rack with stabilizers on the front and sides of the unit. The AMS high-density expansion unit ships with rails and cables to fit the unit.

For rack-mounting purposes, AMS high-density expansion units can be installed in Hitachi Full-Height Solutions racks.

When rack mounting AMS high-density expansion units, observe the following guidelines:

- AMS 2100 storage systems with standard AMS 2000 system racks support three AMS high-density expansion unit.
- AMS 2300 storage systems with standard AMS 2000 system racks support a maximum of four AMS high-density expansion units.
- AMS 2500 storage systems with the Full-Height Solutions rack can be configured with a maximum of 10 AMS high-density expansion units and one RKHE2.
- Cabling must be managed according to the cabling instructions in the *Hitachi AMS2100/2300 Hardware Guide* and the *Hitachi AMS2500 Hardware Guide*. Systems are delivered to the customer site pre-configured, with cables and cable-management hardware shipped in a separate box.

Configuration rules

The following sections describe configuration rules for AMS high-density expansion units used with AMS 2100, AMS 2300, and AMS 2500 storage systems. For additional guidelines to follow when ordering AMS high-density expansion units, see [Ordering checklist on page 5-6](#).

AMS 2100 and AMS 2300 rules

AMS 2100 and AMS 2300 storage systems use the HDS AMS 2000 Family Racks (p-codes 7846630, 7846631, and 7846634). These racks are preconfigured with rails, component power cords, and appropriate power distribution unit (PDU) for the appropriate geographical location.

The AMS high-capacity expansion unit has a different height (4U) than the standard AMS expansion unit, which is 3U. This requires the AMS 2000 Family Rack rails to be repositioned.

The AMS high-density expansion unit requires 4 * 2.5m power cords. The rack provides 2 * 2 foot cords for each component. If using the standard rack, you must order four additional 2.5m power cords.

AMS high-density expansion units come with cable-management hardware. The hardware must be installed properly to ensure warranty and post-warranty support.

To maintain a low center of gravity and maximize rack stability, place all AMS high-density expansion units at the lowest point possible in the rack.

Racks are installed using one of the following configurations:

- Stand-alone installation, where the rack has sufficient clearance to permanently attach stabilization plates
- Bayed installation, where the rack is installed in a row with other racks.

Front and side stabilization plates are required for all stand-alone installations. Front stabilizing plates are included with every AMS 2000 Family rack. The side stabilizing plate (p-code 7846414) is added to the order automatically if AMS high-density expansion units are ordered with the new rack. All HDS stabilization plates have anchoring holes. HDS recommends that stand-alone racks be anchored whenever possible.

If installing expansion units in adjacent racks, bay the racks together and be sure both racks are level and stabilized before installing components in the racks. Baying/interconnecting kits (p-code 7846415) are required for all bay-type installations. Baying kits are used to attach a rack to an adjacent rack. The Baying kits are added automatically to orders containing AMS high-density expansion units.

AMS high-density expansion units can be intermixed with standard trays, using the guidelines in the *Hitachi AMS 2100/2300 Storage System Hardware Guide* and *Hitachi AMS 2500 Storage System Hardware Guide*. The cables provided with the base unit are not long enough to support

extending the AMS high-density expansion unit for service. Therefore, 2 * DF-F800-K3BS (AMS2000 ENC Cable 3m) must be separately ordered to connect the base unit and AMS high-density expansion unit.

AMS 2500 rules

The AMS 2500 storage system uses the Hitachi Full-Height Solutions racks (p-code 7846450). These racks do not contain preconfigured components. Rails, power cords, and the appropriate PDU for the geographical location must be ordered separately.

The AMS 2500 base unit requires rails. However, AMS high-density expansion units includes rails.

Four power cords must be ordered separately for each AMS high-density expansion unit. In addition, four PDUs must be ordered separately for each rack.

AMS high-density expansion units come with cable-management hardware. The hardware must be installed properly to ensure warranty and post-warranty support.

To maintain a low center of gravity and maximize rack stability, all AMS high-density expansion units must be placed at the lowest point in the rack.

Racks are installed using one of the following configurations:

- Stand-alone installation, where the rack has sufficient clearance to permanently attach stabilization plates
- Bayed installation, where the rack is installed in a row with other racks.

Front and side stabilization plates are required for all stand-alone installations. Front stabilizing plates are included with every AMS 2000 Family rack. Side stabilizing plates (p-code 7846414) are added to the order automatically if AMS high-density expansion units are ordered with the new rack. All HDS stabilization plates have anchoring holes. HDS recommends that stand-alone racks be anchored whenever possible.

If installing expansion units in adjacent racks, bay the racks together and be sure both racks are level and stabilized before installing components in the rack. Baying/interconnecting kits (p-code 7846415) are required for all bay-type installations. Baying kits are used to attach a rack to an adjacent rack. The Baying kits are added automatically to orders containing AMS high-density expansion units.

An AMS 2500 storage system with a Full-Height Solutions rack can be configured with up to nine AMS high-density expansion units and one RKHE2 controller tray. A 10th AMS high-density expansion unit can be configured by adding a second rack. However, this requires additional 4 * DF-F800-K5BS cables (AMS 2000 ENC Cable 5m).

Cabling must be managed according to the cabling instructions in the *Hitachi AMS 2100/2300 Storage System Hardware Guide* and *Hitachi AMS 2500 Storage System Hardware Guide*. The systems arrive at their destination fully configured, with cables and cable management hardware shipped in a separate box.

AMS high-density expansion units can be intermixed with standard trays, using the guidelines in the *Hitachi AMS 2100/2300 Storage System Hardware Guide* and *Hitachi AMS 2500 Storage System Hardware Guide*. The cables provided with the base unit are not long enough to support extending the AMS high-density expansion unit for service. Therefore, 2 * DF-F800-K3BS must be separately ordered to connect the base unit and AMS high-density expansion unit.

Floor load ratings

An AMS high-density expansion unit weighs 178.6 pounds (81 kg). The AMS high-density expansion unit has an empty weight of 77 pounds (35 kg.)

Installing AMS high-density expansion units in a rack

Observe the following guidelines when installing AMS high-density expansion units in the Hitachi Full-Height Solutions rack.

- Installation must be performed by two services personnel.
- To ensure a safe experience, installation requires using a mechanical lift device, with at least the capacity and capabilities of the Genie Lift GL-4.
- To maximize service personnel effectiveness, rails are pre-installed.
- To minimize weight, drives and power supplies should be removed before installing the tray. Two service personnel are still required to perform the installation, even if drives and power supplies are removed.
- Drives and ENC cards installed in AMS high-density expansion units are serviced from the top. As a result, the units should be mounted on extending rails to permit access from the top. To ensure rack stability, service personnel must extend a single tray at a time. In addition, a mechanical lift device must be used to minimize weight on the extended rails and maintain stability.
- Servicing AMS expansion units installed higher than 26U in the rack requires the use of a small step ladder (2-to-3 steps).
- Alternatively, equivalent racks can be used to hold AMS high-density expansion units, so long as they meet Hitachi Data Systems' specifications (see [Table 3-3 on page 3-9](#) and [Table 3-4 on page 3-13](#)) and utilize Hitachi-supplied rails.

Bill of materials

The AMS high-density expansion unit is comprised of the components in [Table 5-1](#).

Table 5-1: AMS High-Density Expansion Unit Bill of Materials

No.	Description	Part Number	Quantity	Notes
1	Frame (RKAX) assembly	2852898-A	1	AC100V Plug: EMA 5-15P AC200V Plug: IEC320-C14 Power cables are not included.
2	Bezel assembly	3282121-A	1	
3	AC/DC power supply	3282102-A	4	
4	Enclosure assembly	3282103-B	4	
5	SAS Module (IN) assembly	3282125-A	4	
6	SAS Module (OUT) assembly	3282125-B	4	
7	ENC cable	3276151-B	4	3m

[Table 5-2](#) describes the available drives for the AMS high-density expansion unit.

**Table 5-2: RKAKX Drives for AMS High-Density Expansion Unit
(Minimum of Four Drives, Two Drives per Side)**

P-Code	Description
DF-F800-AVE1KX	AMS 2000 1TB SATA 7.2K RPM HDD High Density Expansion Unit
DF-F800-AVE2KX	AMS 2000 2TB SATA 7.2K RPM HDD High Density Expansion Unit

Ordering checklist

The following tables describe the guidelines to follow when ordering AMS high-density expansion units.



NOTE: An extra DF-f800-K3BS is required when configuring intermixed systems.

Table 5-3: AMS 2100/2300 Rack Configuration Guidelines (Americas)

Description	Part Number	Quantity	Notes
AMS 2000, Domestic	7846630	1	<ul style="list-style-type: none"> Black front bezel/lock back door External dimensions (with panels) <ul style="list-style-type: none"> Width: 1.96 feet (600 mm) Depth: 3.45 feet (1050 mm) Height: 6.82 feet (2080 mm) Fixed rail kits for Hitachi Storage Four 30-amp Nema PDUs with 32 power cords and accessory kit Four L6-30P plugs
High-Density Expansion Unit Power Cables	—	—	<ul style="list-style-type: none"> 10A IEC 320-C14 250V Four per RKAKX tray
Baying/Interconnecting kits	7846415	1	Interconnect multiple rack
Side Stabilizer Kit	7846414	1	Stabilize stand-alone rack

Table 5-4: AMS 2100/2300 Rack Configuration Guidelines (International)

Description	Part Number	Quantity	Notes
AMS 2000, International	7846631	1	<ul style="list-style-type: none"> Black front bezel/lock back door External dimensions (with panels) <ul style="list-style-type: none"> Width: 1.96 feet (600 mm) Depth: 3.45 feet (1050 mm) Height: 6.82 feet (2080 mm) Fixed rail kits for Hitachi Storage Four 32-amp IEC PDUs with 32 power cords and accessory kit Four IEC 309 plugs
High-Density Expansion Unit Power Cables	—	—	<ul style="list-style-type: none"> 10A IEC 320-C14 250V Four per AMS high-density expansion unit
Baying/interconnecting kits	7846415	1	Interconnect multiple rack
Side Stabilizer Kit	7846414	1	Stabilize stand-alone rack

Table 5-5: AMS 2100/2300 Rack Configuration Guidelines (EMEA)

Description	Part Number	Quantity	Notes
AMS 2000, EMEA	7846634	1	<ul style="list-style-type: none"> Black front bezel/lock back door External dimensions (with panels) <ul style="list-style-type: none"> Width: 1.96 feet (600 mm) Depth: 3.45 feet (1050 mm) Height: 6.82 feet (2080 mm) Fixed rail kits for Hitachi Storage Four 32-amp IEC PDUs with 32 power cords and accessory kit Four IEC 309 plugs
High-Density Expansion Unit Power Cables	—	—	<ul style="list-style-type: none"> 10A IEC 320-C14 250V Four per AMS high-density expansion unit
Baying/interconnecting kits	7846415	1	Interconnect multiple rack
Side Stabilizer Kit	7846414	1	Stabilize stand-alone rack

Table 5-6: AMS 2500 with Solutions Rack Configuration Guidelines (America)

Description	Part Number	Quantity	Notes
Full-Height Solutions Rack	7846450	1	<ul style="list-style-type: none"> Black lock front/back doors 42U x 600 mm x 1050 mm w/panels Built-in sliding rails (no rail kit needed) No PDUs No power cords with accessory kit
Solutions PDU 24 - C13	7846466	4	<p>Input</p> <ul style="list-style-type: none"> Voltage: 200-250VAC (50/60 Hz) Line Current: 30A Maximum Load Capacity: 6.90 KVA Power Cord: 10' (2.5m) Connector: NEMA L6-30P <p>Output</p> <ul style="list-style-type: none"> Voltage: 200-250VAC Current: 30A (Total Combined Load) Outlets: 2x 12 IEC C13
High-Density Expansion Unit Power Cables	—	—	<ul style="list-style-type: none"> 10A IEC 320-C14 250V Four per AMS high-density expansion unit
Baying/interconnecting kits	7846415	1	Interconnect multiple rack
Side Stabilizer Kit	7846414	1	Stabilize stand-alone rack

Table 5-7: AMS 2500 with Solutions Rack Configuration Guidelines (International)

Description	Part Number	Quantity	Notes
Full-Height Solutions Rack	7846450	1	<ul style="list-style-type: none"> • Black lock front/back doors • 42U x 600 mm x 1050 mm w/panels • Built-in sliding rails (no rail kit needed) • No PDUs • No power cords with accessory kit
Solutions PDU 24 - C13	7846466 - 24 outlet (NEMA)	4	<p>Input</p> <ul style="list-style-type: none"> • Voltage: 200-250VAC (50/60 Hz) • Line Current: 30A Maximum • Load Capacity: 6.90 KVA • Power Cord: 10' (2.5m) • Connector: NEMA L6-30P <p>Output</p> <ul style="list-style-type: none"> • Voltage: 200-250VAC • Current: 30A (Total Combined Load) • Outlets: 2x 12 IEC C13
High-Density Expansion Unit Power Cables	—	—	<ul style="list-style-type: none"> • 10A IEC 320-C14 250V • Four per AMS high-density expansion unit
Baying/interconnecting kits	7846415	1	Interconnect multiple rack
Side Stabilizer Kit	7846414	1	Stabilize stand-alone rack

Shipping

New systems

Racks configured with AMS high-density expansion units have a number of unique considerations, including:

- Avoiding tipping
- Mobility (caster reliability)
- Trays shipping brackets

To minimize safety risks and potential damage to equipment:

- **Keep a low center of gravity.** AMS high-density expansion units are always located at the bottom of the rack, above the base unit. There should be no expansion tray installed between the AMS 2000 base unit and AMS high-density expansion unit.
- **Observe weight considerations.** The maximum shipping weight, including rack and system components, is 1,253 lbs (568 kg). This weight corresponds to one DF800-RKHE2 and up to four AMS high-density expansion units.
- **Observe height considerations.** The maximum mounted height of system components for shipment is 22U.

- **Observe mounted unit considerations.** All mounted AMS high-density expansion units are attached securely to the rack. Shipping brackets are used to prevent the tray from extending onto its rails, which can cause a safety risk to shipping personnel and the equipment.

Retuning equipment

Rules when returning equipment are the same as those for new systems (stated above).

Installation and support

Installation and support of the AMS high-density expansion units include the following considerations:

- Installation must be performed by two services personnel.
- The customer is responsible for providing an equipment "lift" which is required for installation and service.
- Rails will be pre-installed at the distribution center maximizing service personnel effectiveness.
- To minimize weight, drives can be removed prior to installing the tray. However, two service personnel are still required.
- AMS high-density expansion unit drives and ENC cards are serviced from the top. Access is provided by extending the unit on precision, ball-bearing rails. Only one tray can be extended at a time. During all services, a lift must be placed under the extended unit to minimize the extended weight of the unit on the rack.

High-density expansion unit specifications

The following tables list the specifications for the AMS high-density expansion unit.

Table 5-8: Mechanical Specifications

Specification	AMS High-Density Expansion Unit
Height:	6.93 inches (176 mm) / 4U
Width:	19 inches (483 mm)
Depth:	33 inches (840 mm)
Weight:	178 Lbs (81 Kg)

Table 5-9: Electrical Specifications

Specification	AMS High-Density Expansion Unit
Volts AC:	100/200 (100 to 120/200 to 240)
Frequency (Hz):	50/60
Number of Phases, Cabling:	Single phase plus ground (3 wire)
Steady-state Current (amps):	3.7 x 4/1.9 x 4
Breaking Current (A):	16
Heat Value (kJ/h):	5,190 or less
Required Power ¹ Steady State Current (VA/W): ^{2 3} Starting state (VA/W):	1,480 /1,440 or less 1,480 /1,440 or less
Electrical Insulation Performance Insulation Withstands Voltage: Insulation Resistance:	AC 1,500 V (10 mA, 1 min) DC 500 V, 10 M Ω or more

- ¹ Power requirement in the case of the maximum configuration is shown. When planning facilities such as the uninterrupted power supply (UPS), specify the power factor as 100% for calculation. Value at 100 V/200 V is shown. (Example: 300 W=300 VA) The actual required power may exceed the value shown in the table when the tolerance is included. (Example: 300 W=300 VA) The actual required power may exceed the value shown in the table when the tolerance is included.
- ² The power current of N 2 described in this table is required for operation by a single power supply unit.
- ³ If one of the two power supply units fails, the other power supply provides the total power to the unit that the two supplies together did before the failure. The operating power supply therefore draws the same current as the two supplies did before the failure. To make sure that either power supply can operate in this manner, ensure that the PDUs in the rack can supply twice the normal power of the units plugged into it.

DC-powered racks

This chapter describes of the DC-powered rack (referred to as the “seismic” rack). This rack is designed for DC-powered AMS 2500 storage systems.

Except for the power supplies and front bezels, all components in the DC-powered AMS 2500 base and expansion units are the same as those in the AC-powered units. This means the configuration, operation, and troubleshooting procedures for the DC-powered units are the same as those for the AC-powered units. For more information about DC-powered AMS 2500 storage systems, see the *Hitachi AMS 2500 Storage System Hardware Guide*.

This chapter includes the following key topics.

- [Overview](#)
- [System Components](#)
- [Installation prerequisites](#)
- [Installation](#)
- [Seismic rack specifications](#)
- [Regulatory compliance](#)
- [Certifications](#)
- [Drawings](#)

Overview

DC-powered AMS 2500 storage system consists of the five main components in [Figure 6-1 on page 6-3](#). Item #2 is part of the rack. A system can have several racks, with up to 480 drives. For a complete list of configurations, refer to the *AMS 2100/2300 Storage System Hardware Guide* and *AMS 2500 Storage System Hardware Guide*.

The system is built, configured, and tested in a DC environment at the Hitachi Distribution Center. For Network Equipment Building System (NEBS)-3 installations, the AMS 2500 components are removed from the rack after testing, boxed separately, and shipped with the rack to the customer's site.

The DC-powered system is also available in an AMS 2000 Solutions rack for customers who do not require NEBS-3 or ETSI certification. For this configuration, the system is installed and tested at the Hitachi Data Systems distribution center, but the components can be left in the rack and the system shipped as a unit.

Customers are required to place and anchor the rack, and then connect it to earth ground and the DC power grid. After installing the rack, Hitachi Data Systems personnel install the AMS 2500 components in the rack, and configure and test the system.

[Figure 6-1 on page 6-3](#) shows the front view of an assembled DC-powered AMS 2500 system installed in a seismic rack. The PDU is enlarged for clarity. [Table 6-1 on page 6-3](#) describes the components.

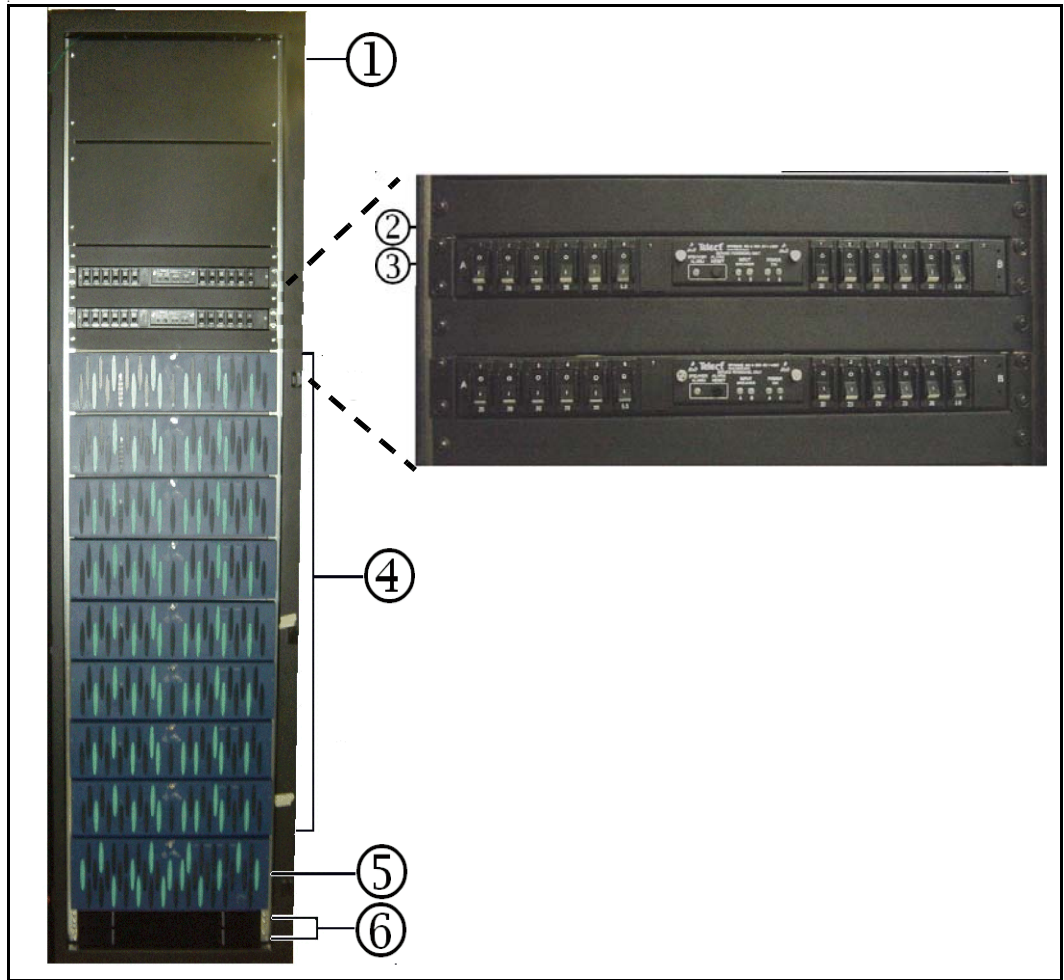

Figure 6-1: AMS 2500 DC-powered Storage System

Table 6-1: AMS 2500 DC-powered Storage System

Item	Name	Description	Item	Name	Description
①	Seismic Rack	Hitachi Data Systems Seismic Rack. Meets NEBS-3 requirements for construction, anchoring, and grounding	④	Expansion Unit	Storage expansion unit, factory model RKAKD, is configured with two redundant DC-powered power supplies and two ENC adapter units
②	1U Spacer	1U spacer above and below both PDUs to allow room to connect the DC power cables (up to 3 required)	⑤	AMS 2500DC	Base unit, factory model RKHE2D. Configured with two redundant DC-powered power supplies, two redundant controllers, two fan units, and four cache backup batteries
③	Power Distribution Unit	Telect PDU 48VDC Circuit Breaker Panel with intelligent alarm system (up to 2 per rack)	⑥	Battery Expansion Units (2)	DC-powered external cache backup batteries, factory model number N1RKD (see Battery expansion unit on page 1-13)

System components

The DC-powered AMS 2500 base and expansion units are functionally and operationally the same as the AC-powered units. Moreover, all components in the units are the same, except for the power supplies and front bezels.

Seismic rack

Figure 6-1 on page 6-3 shows the front view of the Hitachi Data Systems Seismic Rack. To meet NEBS-3 requirements, the seismic rack requires:

- Special procedures listed under [NEBS-3 requirements \(USA\)](#) on page 6-5 during construction.
- Anchoring and grounding during installation. See [Installation](#) on page 6-8.

Figure 6-2 shows the rear view of the seismic rack, with the DC power cables installed. The large green ground wire at the bottom connects the rack frame to the vertical rail that supports the rails supporting the AMS 2500 components. The figure does not show the rack ground and DC power connections to the rack come in at the top of the rack.



Figure 6-2: Seismic Rack - Rear View

Installation prerequisites

Before installing the seismic rack or any components in it, please read the NEBS-3 requirements (or ETSI requirements if installing in Europe). It is imperative that you follow all the installation instructions exactly to meet the requirements.

NEBS-3 requirements (USA)

This section describes the NEBS requirements for installing a seismic rack and AMS 2500 components that will be used in a telecommunications facility. "NEBS Level 3" is a term from Bellcore special report, SR-3580, and means the equipment meets all of the requirements of GR-63-CORE and GR-1089-CORE.

NEBS Level 3 has strict specifications for:

- Fire suppression
- Thermal margin testing
- Vibration resistance (earthquakes),
- Airflow patterns
- Acoustic limits
- Failover

It also includes partial operational requirements such as:

- Chassis fan failures
- Failure severity levels
- RF emissions and tolerances
- Testing/certification requirements

In addition to these operational requirements, NEBS-3 requires the equipment to pass a set of non-operational tests, including high and low temperatures, high humidity, drop, and rain. The AMS 2500 equipment passed all of these tests.



NOTE: Verizon and AT&T use their own NEBS checklists. Both accept the TCG checklist that can be found on their Web sites.

Rack and assembly

This section complies with NEBS-3 GR-1089-CORE, Issue 4, Section 9.6 Equipment Unit Bonding and Grounding. NEBS-3 requires you to perform the following steps when building a rack:

- Clean all parts to be joined before assembly.
- Apply anti-oxidant compounds to the surfaces to be joined before assembly.
- Fasten the internal rack structures together with thread forming screws and paint-piercing star lock washers, and apply antioxidants during assembly.

Anchoring the rack

The seismic rack must be anchored to the concrete floor with anchoring bolts that meet NEBS-3 specifications. For more information, see the anchoring kit specifications in [Installation on page 6-8](#).

Shelf level configuration

Use thread forming screws and paint piercing lock washers to mount all hardware in the rack. See the example in [Installation on page 6-8](#).

Bonding and grounding

This section complies with NEBS-3 GR-1089-CORE, Issue 4, Sections 9.9.2 and 9.9.3, Connectors, and Section 9.7.1, Connectors and Connection Methods for Equipment Unit Assemblies.

- Main ground connection to the rack:
 - Each ground lead must be secured with its own bolt or thread-forming screw.
 - Bolt assembly size and torque specifications for securing the two hole compression lug to the rack must be followed when installing the rack. See the Installation section for this information.
 - Procedures for cleaning and treating the surface areas surrounding the compression lugs during installation must followed when installing the rack. See the Installation section for this information
- Other grounding connectors:
 - Bare conductors must be cleaned and antioxidant materials applied before crimp connections during installation. See the Installation section for details.
 - Install a crimp-type lug on each grounding conductor. Fasten the lug to the chassis or rack with a thread forming screw. Install paint-piercing star lock washers on both sides of the lug to ensure positive ground and thread locking.
 - Each grounding conductor must be attached to the chassis or rack with a separate screw or bolt. Do not connect multiple ground wires to a chassis or to the rack with a single screw or bolt.

Wiring and cabling

The intrabuilding port(s) of the equipment or subassembly is suitable for connection to intrabuilding or unexposed wiring or cabling only. The intra-building port(s) of the equipment or subassembly **MUST NOT** be metallicity connected to interfaces that connect to the OSP or its wiring. These interfaces are designed for use as intra-building interfaces only (Type 2 or Type 4 ports, as described in GR-1089-CORE, Issue 4) and require isolation from the exposed OSP cabling. The addition of Primary Protectors is not sufficient protection to connect these interfaces metallicity to outside plant (OSP) wiring.

To meet NEBS-3 requirements, use shielded, twisted-pair (STP) Ethernet cable. The shield must be grounded at both ends of the cable. This is required for installation.

NEBS-3 testing

NEBS-3 testing was completed at the following facility:

MET Laboratories, Inc.
33439 Western Ave.
Union City, CA 94587
510-489-6300
<http://www.metlabs.com>

NEBS-3 test results and certification

The AMS 2500 DC-powered storage system, as described in this chapter, passed NEBS-3 test requirements and is certified for NEBS-3 installations, as of May 14, 2009.

The Certifications section in this chapter shows the certificates and test results.

ETSI requirements (Europe)

In addition to NEBS-3 testing, the DC-powered AMS 2500 system was also tested at MET Laboratories for compliance with the specifications set forth by the European Telecommunications Standards Institute (ETSI) for equipment installed in telecommunications facilities.



NOTE: The European Telecommunications Standards Institute is a non-profit organization that establishes telecommunications standards for Europe. ETSI guidelines are voluntary and almost always comply with standards produced by international bodies.

ETSI testing

ETSI testing was completed at the following facility:

MET Laboratories, Inc.
33439 Western Ave.
Union City, CA 94587
510-489-6300
<http://www.metlabs.com>

ETSI test results and certification

The AMS 2500 DC-powered storage system, as described in this chapter, passed NEBS-3 test requirements and is certified for ETSI installations, as of May 14, 2009.

The Certifications section in this chapter shows the certificates and test results.

Installation

This section describes how to install Hitachi Data Systems seismic rack. For information about installing DC-powered storage units in the rack, see the *Hitachi AMS 2500 Storage System Hardware Guide*.



CAUTION! Please read the installation prerequisites and requirements before beginning the installation.

Installing a seismic rack

It is the customer's responsibility to place, anchor, ground, and connect the rack to the DC power grid. Hitachi Data Systems is not responsible for rack placement and anchoring.

Once the rack is installed, Hitachi Data Systems personnel will install the AMS 2500 components in the rack, and will configure and test the system.

Anchoring the rack

Rack anchoring must be completed by an experienced installer who is familiar with seismic installations that meet local building codes and can obtain the appropriate anchor bolts.

The seismic rack does not have leveling feet or casters. It must be moved about on a pallet. The Seismic Rack vendor, Mayville Products Corp., offers anchoring kits. These may be ordered from the vendor from the following pages on the vendor's Web site:

http://www.apwmayville.com/products_product_detail.aspx?productID=2676

http://www.apwmayville.com/products/product_detail.aspx?productID=2677

Anchoring kit

Table 6-2 lists the specifications of the anchoring kit.

Table 6-2: Anchoring Kit Specifications

Item	Specification
Anchor length	7.5 inches (131 mm)
Approvals	ETA Option 1, Shock BZS, Fire IBMB, Fire Warrington Report, ICC-ES/ AC 193
Base materials	Concrete (cracked), Concrete block (solid), Stone (hard natural)
Environmental conditions	Inside dry
Min. thickness of base material	4 inches (160 mm)
Anchor type	Mechanical
Working principle	Torque controlled expansion
Type of fixing	Through-fastening
Effective embedment depth	3.15 inches (80 mm)
Baseplate clearance hole	0.79 inch (20 mm)

Table 6-2: Anchoring Kit Specifications (Continued)

Item	Specification
Drill bit diameter	46/64 inch (18 mm)
Hole depth (mm)	4.02 inches (105 mm)
Required tightening torque (Nm)	80
Wrench size (mm)	3/4 inch (19 mm)
Package quantity	20
Additional product information	The indicated load value applies to non-cracked concrete C20/25, no edge distance and spacing influence.
Max. thickness fastened	1 inch (25 mm)
Min. thickness of base material	4 inches (160 mm)

Grounding the rack components

Grounding cables between components of the rack are constructed with two-hole compression lugs at both ends of the cable (see [Figure 6-3](#)).

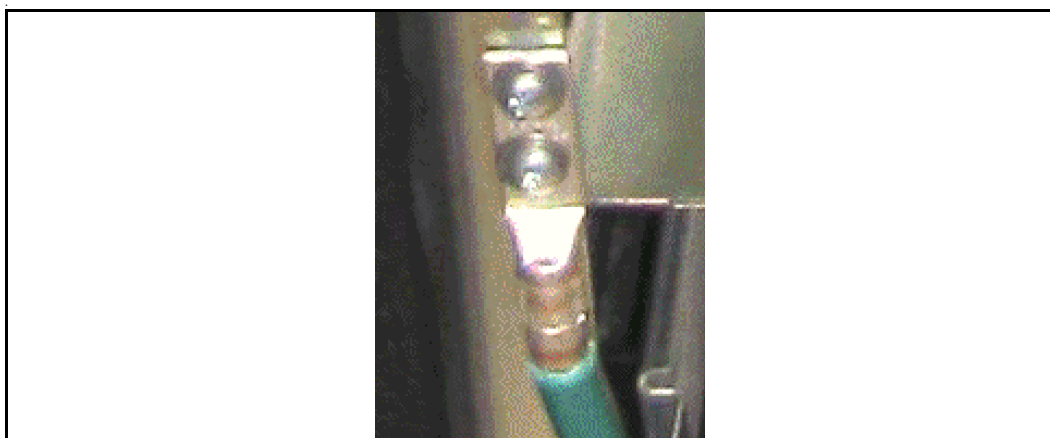

Figure 6-3: Seismic Rack Ground Connection

To connect the lug to the rack:

1. Remove any paint overspray from the area where the lug will attach to the rack.
2. Clean the rack surface where the ground lug will be attached and remove any residue and paint particles.



NOTE: IMPORTANT! To meet NEBS-3 requirements, the surface where the ground lug attaches to the rack must be cleaned and polished to a bright finish and anti-oxidant applied to the area before the ground lug is attached to the rack.

3. Clean the connector lug.
4. Apply anti-oxidant compound to both the area where the lug will attach to the rack and to the side of the connector lug that will contact the rack.

- Fasten the grounding lug to the rack with two thread-forming screws or use captive bolts if they are installed in the rack. Install star lock washers above and below the compression lug. If the lug is installed with captive bolts (nominally 1/4 inch diameter, carbon steel) tighten the nuts as specified in [Table 6-3](#).

Table 6-3: Ground Lug Torque Specifications

Bolt Size	Torque - foot lbs.
1/4-20	6
1/4-28	7
The following torque values are for SAE Grade 5 (medium strength) steel bolts, dry lubricated, using SAE Grade 5 Nuts	

Mounting components in the rack

NEBS-3 requires special fasteners and paint-piercing lock washers when installing storage components in the rack. These fasteners and washers are described in this section.

Fasteners





To meet the NEBS-3 code, use screws that form their own threads in the rack frame, ensuring good electrical contact with the rack as well as a tight mechanical bond. These are sheet-metal screws and are shown in the following illustration and on the detailed drawings at the end of this chapter.

Paint piercing lock washers

In addition to the fasteners described above, use lock washers that pierce the paint or other finish (alodine, etc.) on the installed units and the rack to ensure that the units are securely grounded to the rack. A star washer usually fills this requirement. A star washer has internal or external teeth that lock the fastener to the unit as well as pierce the finish and contact the metal underneath. The fastener, in turn, is grounded to the rack via the threads in the rack frame.

[Table 6-4 on page 6-11](#) shows examples of internal and external tooth star washers.

Table 6-4: Fasteners and Star Washers

<p>Internal Tooth Star Washer</p> 	<p>External Tooth Star Washer</p> 	<p>Installed Fastener with Star Washer</p> 
<p>Captive 1/4-20 stud for ground terminals. See Table 6-3 above.</p> 	<p>Thread forming screw: 10-32 x 3/8 pan head Phillips drive steel zinc finish.</p> 	

Seismic rack specifications

[Table 6-5](#) lists the specifications for the Hitachi Data Systems seismic rack.

Table 6-5: Seismic Rack Specifications

Item	Specification
Rack Dimensions (inches / mm)	84H (45U) x 24W x 36 D
Weight (lb. / kg)	570 / 259
Service Clearance, front and rear (inches /mm)	40 /1015 (see Figure 6-4 on page 6-12)

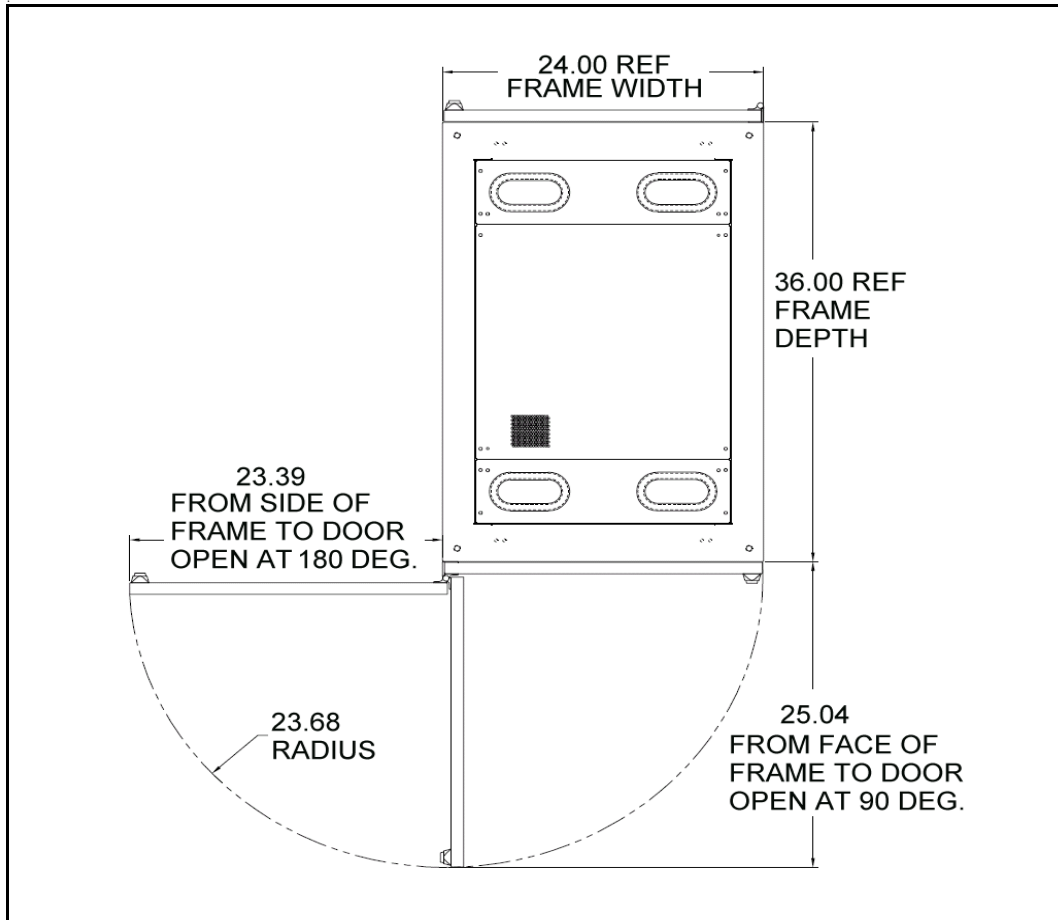

Figure 6-4: Service Clearances

Regulatory compliance

The DC-powered AMS 2500 equipment has been tested and certificated for the standards in [Table 6-6](#).

Table 6-6: Regulatory Compliance

Standard	Specification	Mark on Product	Country
Electronic emission control	FCC Part 15 Subpart B Class A	Yes (FCC)	U.S.A
Radio inteference voluntary control	VCCI Class A	Yes (VCCI)	Japan
Limits for harmonic current emissions	JIS C61000-3-2	None	Japan
Electronic emission control	ICES-003 Class A	Yes (ICES-003)	Canada
Electronic emission control	AS/NZS 3548: 1995,A1,A2	None	Australia
Electronic emissions certification	EN 50022: 1998/A1: 2000/A2: 2003	Yes (CEmarking)	EU
	EN 61000-3-2: 2000/A1: 2001/A2: 2005		
	EN 61000-3-3: 1995/A1: 2001		
	EN 55024: 1998/A1: 2001/A2: 2003		
	EN 61000-4-2: 1995/A1: 1998/A2: 2001		
	EN 61000-4-3: 2002/A2: 2002		
	EN 61000-4-4: 1995/A1: 2001/A2: 2003		
	EN 61000-4-5: 1995A1: 2001		
	EN 61000-4-6: 1996/A1: 2001		
	EN 61000-4-8: 1993/A1: 2001		
EN 61000-4-11: 1994/A1: 2001			
Electronic emission control	CNS 13438 Class A	Yes (BSMI)	Taiwan
Electronic emission control	KN22	Yes (RRL)	Korea
	KN6100-4		
Safety certification	UL 60950-1	Yes (TUV)	EU/U.S.A
	CAN/CSA-C22.2		
Safety certification	EN 60950-1	Yes (GS)	EU
Safety certification	GOST R60950-2002	Yes (GOST)	Russia
	GOST R51318.22-99		
	GOST R51318.24-99		
	GOST R51317.3.2-99		
	GOST R51317.3.3-99		
Safety certification	IEC 60950-1	Yes(IRAM)	Argentina

Certifications

This section provides the NEBS-3 certifications that show that the AMS 2500 storage system has passed the NEBS-3 test requirements.



Figure 6-5: NEBS-3 Compliance Testing

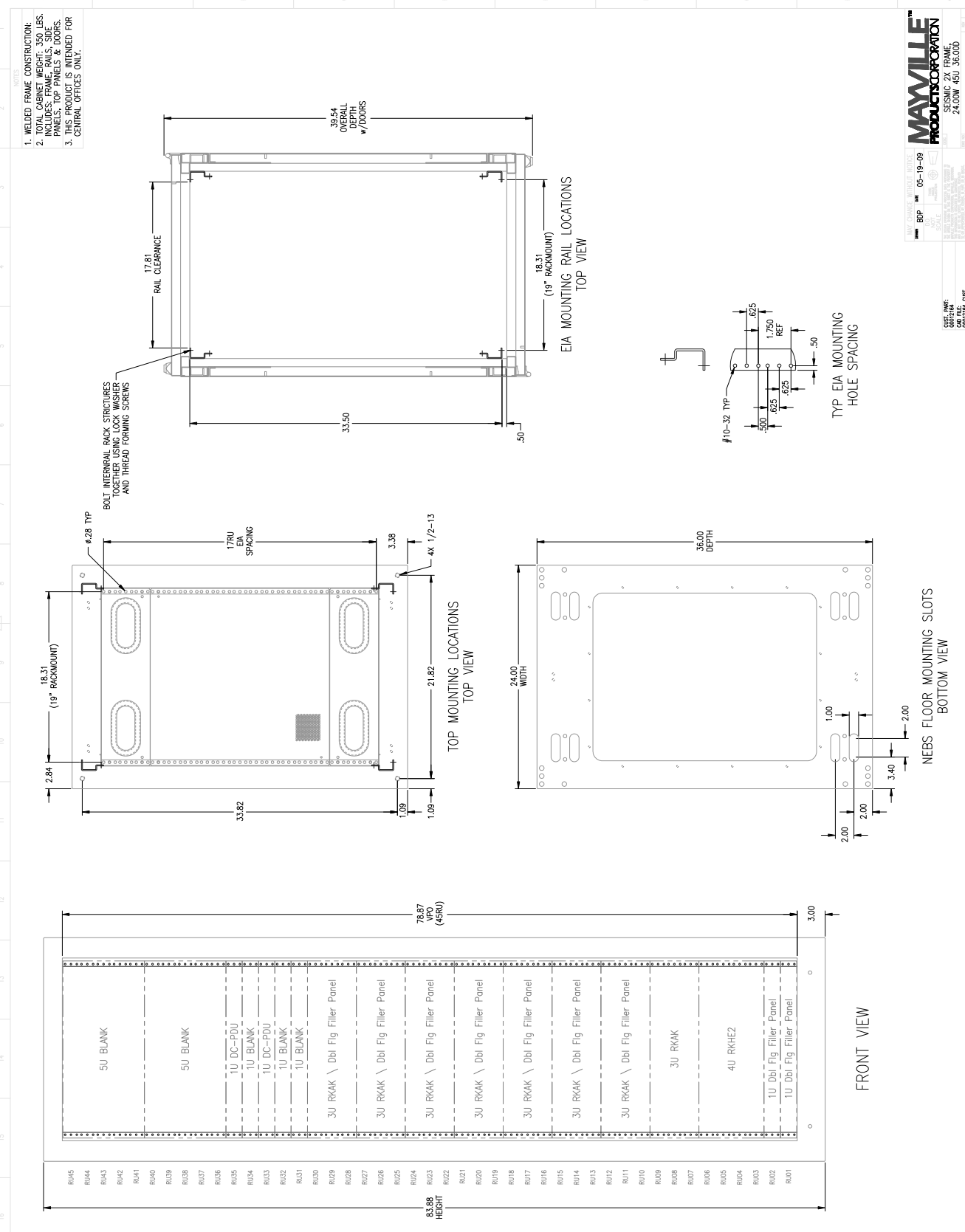

Figure 6-6: NEBS-3 Shelf Level Compliance Testing

Drawings

This section includes a set of manufacturers drawings of the seismic rack used to contain the components of the DC-powered AMS 2500. Please refer to the following drawing for details of the components and dimensions of the APWMayville Seismic x2 Frame (rack).

- Overall dimensions: Q0012068_CUST_C02_sht1of3.pdf
- Grounding system: Q0012068_CUST_C02_sht2of3.pdf
- Service clearance: Q0012068_CUST_C02_sht3of3.pdf



DC-powered racks

6-17

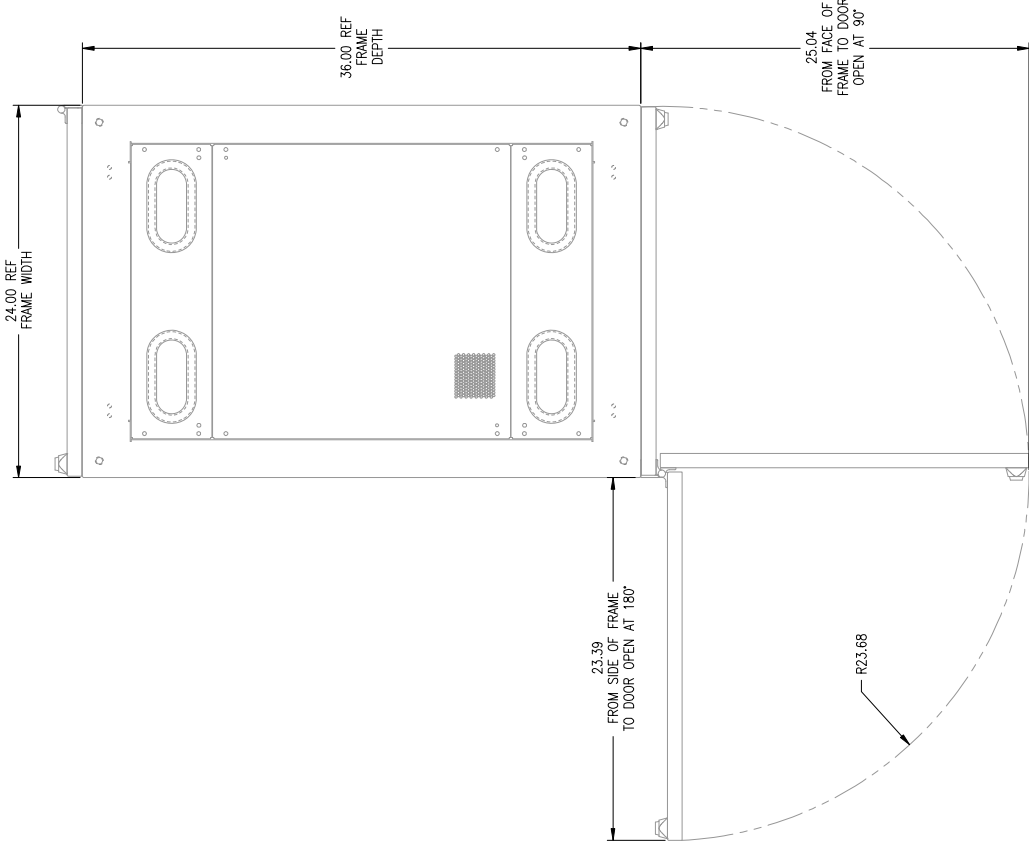

MAYVILLE™
PRODUCTS CORPORATION
 SEISMIC 2X FRAME,
 24.00W 45U 36.00D
 Q0012164_CUST

ANY CHANGE WITHOUT NOTICE
 DATE: 05-19-09
 BOP: 05-19-09
 SCALE: 1/8" = 1'-0"

THE ABOVE DRAWING IS THE PROPERTY OF MAYVILLE PRODUCTS CORPORATION. IT IS TO BE USED ONLY FOR THE PROJECT AND SITE SPECIFICALLY IDENTIFIED HEREON. IT IS NOT TO BE REPRODUCED, COPIED, EITHER WHOLLY OR IN PART, OR TRANSMITTED IN ANY FORM OR BY ANY MEANS, ELECTRONIC OR MECHANICAL, INCLUDING PHOTOCOPYING, RECORDING, OR BY ANY INFORMATION STORAGE AND RETRIEVAL SYSTEM, WITHOUT THE WRITTEN PERMISSION OF MAYVILLE PRODUCTS CORPORATION.

CUST. PART:
 CUST. FILE:
 Q0012164_CUST
 SHEET 3 OF 3

1	2	3	4	5	6	7	8	9	10	11	12	13
---	---	---	---	---	---	---	---	---	----	----	----	----

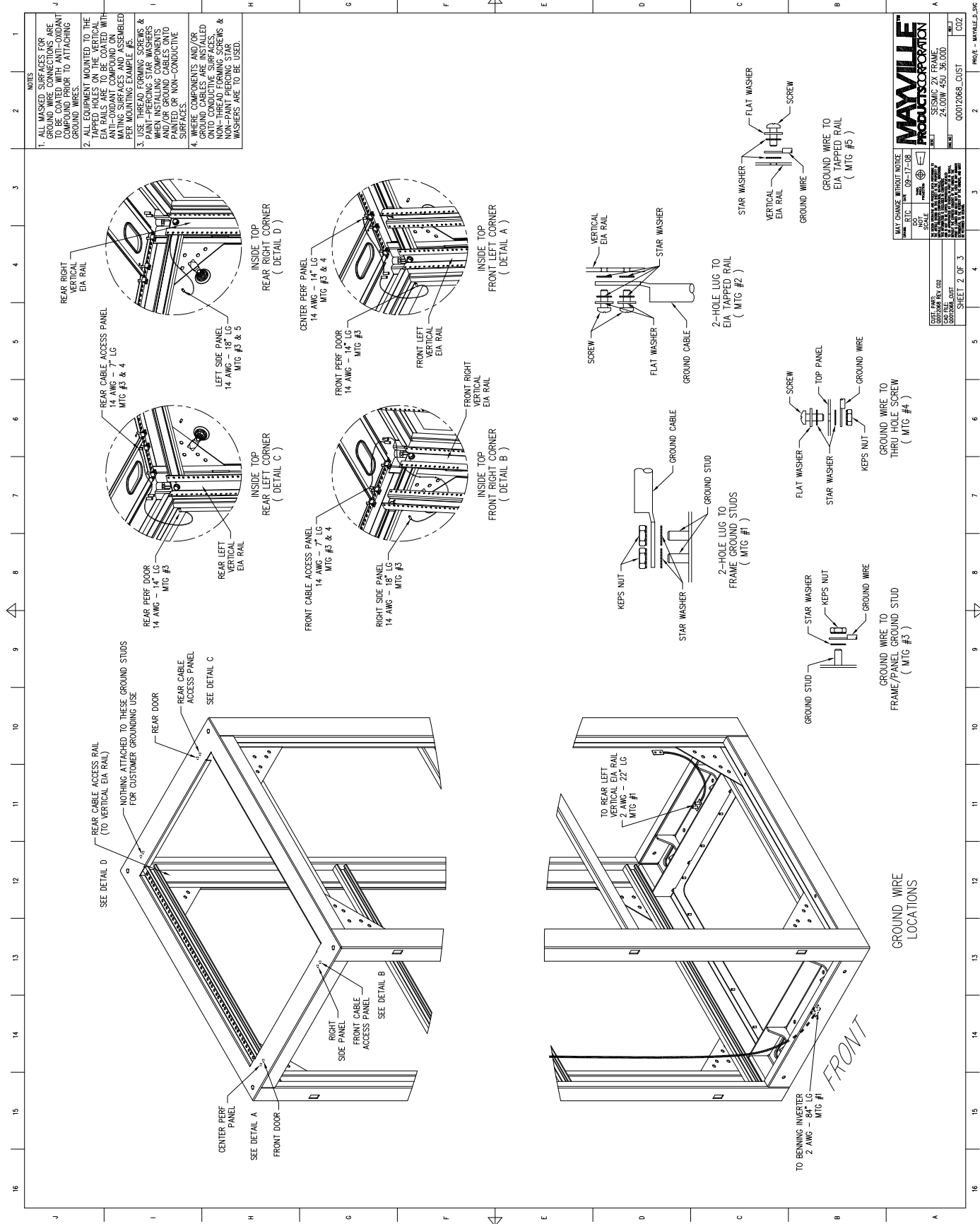

- NOTES**
1. ALL MASKED SURFACES FOR THE COMPONENTS ARE TO BE COATED WITH AN OXIDANT COMPOUND PRIOR TO ATTACHING GROUND WIRES.
 2. ALL EQUIPMENT MOUNTED TO THE RACKS MUST BE INSTALLED ON AN ANTI-OXIDANT COMPOUND ON MATING SURFACES AND ASSEMBLED PER MOUNTING EXAMPLE #5.
 3. USE 18 AWG GROUNDING WASHERS & KEPS NUTS TO SECURE GROUND CABLES AND/OR GROUND CABLES ONTO CONDUCTIVE SURFACES. NON-PAINTELECTRIC SCREWS & WASHERS ARE TO BE USED.
 4. WHERE COMPONENTS AND/OR GROUND CABLES ARE INSTALLED ONTO CONDUCTIVE SURFACES, NON-PAINTELECTRIC SCREWS & WASHERS ARE TO BE USED.

MAY CHANGE WITHOUT NOTICE		MAY 2017	
REV. NO.		DATE	
001	09-27-17-08	REVISED FOR 2000 SERIES	
002	03-06-18-02	REVISED FOR 2000 SERIES	
003	03-06-18-02	REVISED FOR 2000 SERIES	
004	03-06-18-02	REVISED FOR 2000 SERIES	
005	03-06-18-02	REVISED FOR 2000 SERIES	
006	03-06-18-02	REVISED FOR 2000 SERIES	
007	03-06-18-02	REVISED FOR 2000 SERIES	
008	03-06-18-02	REVISED FOR 2000 SERIES	
009	03-06-18-02	REVISED FOR 2000 SERIES	
010	03-06-18-02	REVISED FOR 2000 SERIES	
011	03-06-18-02	REVISED FOR 2000 SERIES	
012	03-06-18-02	REVISED FOR 2000 SERIES	
013	03-06-18-02	REVISED FOR 2000 SERIES	
014	03-06-18-02	REVISED FOR 2000 SERIES	
015	03-06-18-02	REVISED FOR 2000 SERIES	
016	03-06-18-02	REVISED FOR 2000 SERIES	
017	03-06-18-02	REVISED FOR 2000 SERIES	
018	03-06-18-02	REVISED FOR 2000 SERIES	
019	03-06-18-02	REVISED FOR 2000 SERIES	
020	03-06-18-02	REVISED FOR 2000 SERIES	
021	03-06-18-02	REVISED FOR 2000 SERIES	
022	03-06-18-02	REVISED FOR 2000 SERIES	
023	03-06-18-02	REVISED FOR 2000 SERIES	
024	03-06-18-02	REVISED FOR 2000 SERIES	
025	03-06-18-02	REVISED FOR 2000 SERIES	
026	03-06-18-02	REVISED FOR 2000 SERIES	
027	03-06-18-02	REVISED FOR 2000 SERIES	
028	03-06-18-02	REVISED FOR 2000 SERIES	
029	03-06-18-02	REVISED FOR 2000 SERIES	
030	03-06-18-02	REVISED FOR 2000 SERIES	
031	03-06-18-02	REVISED FOR 2000 SERIES	
032	03-06-18-02	REVISED FOR 2000 SERIES	
033	03-06-18-02	REVISED FOR 2000 SERIES	
034	03-06-18-02	REVISED FOR 2000 SERIES	
035	03-06-18-02	REVISED FOR 2000 SERIES	
036	03-06-18-02	REVISED FOR 2000 SERIES	
037	03-06-18-02	REVISED FOR 2000 SERIES	
038	03-06-18-02	REVISED FOR 2000 SERIES	
039	03-06-18-02	REVISED FOR 2000 SERIES	
040	03-06-18-02	REVISED FOR 2000 SERIES	
041	03-06-18-02	REVISED FOR 2000 SERIES	
042	03-06-18-02	REVISED FOR 2000 SERIES	
043	03-06-18-02	REVISED FOR 2000 SERIES	
044	03-06-18-02	REVISED FOR 2000 SERIES	
045	03-06-18-02	REVISED FOR 2000 SERIES	
046	03-06-18-02	REVISED FOR 2000 SERIES	
047	03-06-18-02	REVISED FOR 2000 SERIES	
048	03-06-18-02	REVISED FOR 2000 SERIES	
049	03-06-18-02	REVISED FOR 2000 SERIES	
050	03-06-18-02	REVISED FOR 2000 SERIES	
051	03-06-18-02	REVISED FOR 2000 SERIES	
052	03-06-18-02	REVISED FOR 2000 SERIES	
053	03-06-18-02	REVISED FOR 2000 SERIES	
054	03-06-18-02	REVISED FOR 2000 SERIES	
055	03-06-18-02	REVISED FOR 2000 SERIES	
056	03-06-18-02	REVISED FOR 2000 SERIES	
057	03-06-18-02	REVISED FOR 2000 SERIES	
058	03-06-18-02	REVISED FOR 2000 SERIES	
059	03-06-18-02	REVISED FOR 2000 SERIES	
060	03-06-18-02	REVISED FOR 2000 SERIES	
061	03-06-18-02	REVISED FOR 2000 SERIES	
062	03-06-18-02	REVISED FOR 2000 SERIES	
063	03-06-18-02	REVISED FOR 2000 SERIES	
064	03-06-18-02	REVISED FOR 2000 SERIES	
065	03-06-18-02	REVISED FOR 2000 SERIES	
066	03-06-18-02	REVISED FOR 2000 SERIES	
067	03-06-18-02	REVISED FOR 2000 SERIES	
068	03-06-18-02	REVISED FOR 2000 SERIES	
069	03-06-18-02	REVISED FOR 2000 SERIES	
070	03-06-18-02	REVISED FOR 2000 SERIES	
071	03-06-18-02	REVISED FOR 2000 SERIES	
072	03-06-18-02	REVISED FOR 2000 SERIES	
073	03-06-18-02	REVISED FOR 2000 SERIES	
074	03-06-18-02	REVISED FOR 2000 SERIES	
075	03-06-18-02	REVISED FOR 2000 SERIES	
076	03-06-18-02	REVISED FOR 2000 SERIES	
077	03-06-18-02	REVISED FOR 2000 SERIES	
078	03-06-18-02	REVISED FOR 2000 SERIES	
079	03-06-18-02	REVISED FOR 2000 SERIES	
080	03-06-18-02	REVISED FOR 2000 SERIES	
081	03-06-18-02	REVISED FOR 2000 SERIES	
082	03-06-18-02	REVISED FOR 2000 SERIES	
083	03-06-18-02	REVISED FOR 2000 SERIES	
084	03-06-18-02	REVISED FOR 2000 SERIES	
085	03-06-18-02	REVISED FOR 2000 SERIES	
086	03-06-18-02	REVISED FOR 2000 SERIES	
087	03-06-18-02	REVISED FOR 2000 SERIES	
088	03-06-18-02	REVISED FOR 2000 SERIES	
089	03-06-18-02	REVISED FOR 2000 SERIES	
090	03-06-18-02	REVISED FOR 2000 SERIES	
091	03-06-18-02	REVISED FOR 2000 SERIES	
092	03-06-18-02	REVISED FOR 2000 SERIES	
093	03-06-18-02	REVISED FOR 2000 SERIES	
094	03-06-18-02	REVISED FOR 2000 SERIES	
095	03-06-18-02	REVISED FOR 2000 SERIES	
096	03-06-18-02	REVISED FOR 2000 SERIES	
097	03-06-18-02	REVISED FOR 2000 SERIES	
098	03-06-18-02	REVISED FOR 2000 SERIES	
099	03-06-18-02	REVISED FOR 2000 SERIES	
100	03-06-18-02	REVISED FOR 2000 SERIES	

DC-powered racks



A

General specifications

This appendix describes the physical, environmental, and electrical requirements for Hitachi AMS 2100, 2300, and 2500 storage systems. The key sections in this appendix are:

- ❑ [Dimensions and weight](#)
- ❑ [Environmental specifications](#)
- ❑ [Electrical requirements](#)
- ❑ [Regulatory compliance](#)
- ❑ [Safety certification](#)
- ❑ [iSCSI connection specifications](#)

Dimensions and weight

The floor space at the installation site must be strong enough to support the combined weight of the AMS 2000 Family base and expansion units, rack, and associated equipment. The total weight of the AMS 2000 Family base and expansion units depends on the number of drives installed.

Table A-1 describes the physical dimensions and weight for the Hitachi AMS 2000 Family base, expansion, and high-density expansion units.

Table A-1: Unit Dimensions and Weight

Height	Width	Depth	Weight (Fully Populated)
Hitachi AMS 2100 Base Unit			
6.85 inches (174 mm)	19.02 inches (483 mm)	25.55 inches (649 mm)	112.2 pounds (51 kg)
Hitachi AMS 2300 Base Unit			
6.85 inches (174 mm)	19.02 inches (483 mm)	25.55 inches (649 mm)	112.2 pounds (51 kg)
Hitachi AMS 2500 Base Unit			
6.85 inches (174 mm)	19.02 inches (483 mm)	25.55 inches (649 mm)	101.2 pounds (46 kg)
Hitachi AMS Expansion Unit			
5.08 inches (129 mm)	19.02 inches (483 mm)	25.55 inches (649 mm)	88 pounds (40 kg)
Hitachi AMS High-density Expansion Unit			
6.92 inches (176 mm)	19.02 inches (483 mm)	33.07 inches (840 mm)	178.2 pounds (81 kg)

Environmental specifications

Table A-2 describes the environmental specifications for Hitachi AMS 2100, 2300, and 2500 storage systems and high-density expansion units.

Table A-2: Environmental Specifications

Hitachi AMS 2100, 2300, and 2500 Storage Systems		
Specification	Range (Operating Environment)	Range (Non-operating Environment)
Temperature	41° to 104°F (5° to 40°C)	14° to 122°F (-10° to 50°C)
Relative humidity	5% to 85%, non-condensing	5% to 100%, non-condensing
Altitude	0.98425 to 9.8425 feet (-300 to 3,000 mm)	0.98425 to 39.370 feet (-300 to 12,000 mm)
Vibration	2.5 ms	5.0 ms
Acoustic noise	60 dB (AMS 2100/2300) 72 dB (AMS 2500)	—
Radio frequency	Complies with FCC Class A	Complies with FCC Class A
Hitachi High-Density Expansion Units		
Temperature	41° to 95°F (5° to 35°C)	

Electrical requirements

Table A-3 describes the electrical requirements for Hitachi AMS 2100, 2300, and 2500 storage systems.

Table A-3: Electrical Requirements

Specification	Specification
AC power	100/200 VAC (100 to 120/200 to 240)



NOTE: Electrical requirements for the Hitachi AMS 2000 Family rack can be found in [Table 3-3 on page 3-9](#).

Regulatory compliance

Table A-4 provides the compliance information for Hitachi AMS 2100, 2300, and 2500 storage systems.

Table A-4: Regulatory Compliance

Country	Specification
United States	FCC Part15 Subpart B Class A
Canada	ICES-003 Class A
Japan	VCCI Class A
Japan	JIS C61000-3-2
Australia	AS/NZS 3548:1995,A1,A2
European Union	EN 50022:1998/A1:2000/A2:2003 EN 61000-3-2:2000/A1:2001/A2:2005 EN 61000-3-3:1995/A1:2001 EN 55024:1998/A1:2001/A2:2003 EN 61000-4-2:1995/A1:1998/A2:2001 EN 61000-4-3:2002/A2:2002 EN 61000-4-4:1995/A1:2001/A2:2003 EN 61000-4-5:1995A1:2001 EN 61000-4-6:1996/A1:2001 EN 61000-4-8:1993/A1:2001 EN 61000-4-11:1994/A1:2001
China	CCC
Taiwan	CNS 13438 Class A
Korea	KN22 KN6100-4

Safety certification

Table A-5 provides the safety certification for Hitachi AMS 2100, 2300, and 2500 storage systems.

Table A-5: Regulatory Compliance

Country	Specification
United States and European Union	UL 60950-1
Canada	CAN/CSA-C22.2
European Union	EN 60950-1
Russia	GOST R60950-2002 GOST R51318.22-99 GOST R51318.24-99 GOST R51317.3.2-99 GOST R51317.3.3-99
Argentina	IEC 60950-1

iSCSI connection specifications

To configure an AMS 2100, 2300, or 2500 iSCSI storage system, use network switches that comply with the following standards.

- IEEE 802.1D STP
- IEEE 802.1w RSTP
- IEEE 802.3 CSMA/CD
- IEEE 802.3u Fast Ethernet
- IEEE 802.3z 1000BaseX
- IEEE 802.1Q Virtual LANs
- IEEE 802.3ad Dynamic LACP
- RFC 768 UDP
- RFC 783 TFTP
- RFC 791 IP
- RFC 793 TCP
- RFC 1157 SNMP v1
- RFC 1213 MIB II
- RFC 1757 RMON
- RFC 1901 SNMP v2

Installation planning checklist

Complete the checklist below (online or hardcopy) to verify that all installation requirements for the Hitachi AMS 2000 Family storage system have been met. Successful completion of this checklist (Yes is checked for all entries) will ensure smooth and efficient installation of the units.

Definition of terms:

- Data center: The room at the customer site in which the units will be installed.
- Equipment: The hardware delivered to the customer site.
- Location: The specific location in the data center (area or “footprint” on the floor) where the units will be installed

Customer Information		Date:	
Company:			
Address:			
Contact:		Phone:	
		Mobile:	
		Email:	
Contact:		Phone:	
		Mobile:	
		Email:	
Hitachi Data Systems Information			
Contact:		Phone:	
		Mobile:	
		Email:	
Contact:		Phone:	
		Mobile:	
		Email:	
Notes			

Installation and Planning Checklist	Yes	No
Safety		
Is the data center equipped to protect equipment from fire?		
Is the data center free of hazards (for example, cables that obstruct access)?		
Delivery		
Is the receiving area adequate for equipment delivery and unloading?		
Does the equipment fit through doors, halls, elevators, and stairs?		
Do the floors, elevators, stairs, and ramps support the weight of the equipment?		
Storage		
If the equipment will be stored after delivery and prior to installation, does the storage location meet the environmental requirements for the Hitachi AMS 2100/2300/2500 storage system?		
Facilities		
Is the data center fully operational (for example, power, air conditioning, cabling, fire protection system)?		
Does the data center have a tiled raised floor?		
Does the data center provide adequate protection from ESD?		
Does the data center provide adequate protection from electrical/radio frequency interference?		
Does the data center provide adequate protection from dust, pollution, and particulate contamination?		
Does the data center provide adequate acoustic insulation for operation of the Hitachi AMS 2100/2300/2500 storage system?		
Is the customer-supplied hardware (for example, connectors, receptacles, cables) ready for the installation?		
Physical		
Does the location meet the requirements for service clearance and cable routing (for example, floor cutouts)?		
Does the location meet the requirements for floor load rating?		
Power		
Does the data center meet the AC input power requirements?		
Does the data center meet the circuit breaker and plug requirements?		
Does the data center meet the requirements for connection to the Hitachi AMS 2100/2300/2500 storage system?		
Environmental		
Does the data center meet the requirements for temperature?		
Does the data center meet the requirements for humidity?		
Does the data center meet the requirements for altitude?		
Does the data center meet the requirements for air flow?		
Does the data center meet the requirements for vibration and shock?		
Operational		
Does the data center provide a LAN (or phone line)?		
Does the data center provide a LAN for Storage Navigator?		
Does the location meet the cable length requirements for the front end directors?		
Does the location meet the requirements for attaching external storage to the Hitachi AMS 2100/2300/2500 storage system?		

Hitachi Data Systems

Corporate Headquarters

750 Central Expressway
Santa Clara, California 95050-2627
U.S.A.
Phone: +1 408 970 1000
www.hds.com
info@hds.com

Asia Pacific and Americas

750 Central Expressway
Santa Clara, California 95050-2627
U.S.A.
Phone: +1 408 970 1000
info@hds.com

Europe Headquarters

Sefton Park
Stoke Poges
Buckinghamshire SL2 4HD
United Kingdom
Phone: +44 (0)1753 618000
info.eu@hds.com



MK-98DF8149EN-09